

# PRO SERIES 37" WIDEBELT SANDER 10HP MANUAL



LAGUNA TOOLS  
2072 Alton Parkway  
Irvine, California 92606  
Ph: 800.234.1976  
[www.lagunatools.com](http://www.lagunatools.com)

MSANWB37X75-10-0197

© 2018, Laguna Tools, Inc. LAGUNA® and the LAGUNA Logo® are the registered trademarks of Laguna Tools, Inc. All rights reserved.

LAGUNA



## **Safety Rules**

**As with all machinery there are certain hazards involved with the operation and use. Using it with caution will considerably lessen the possibility of personal injury. However, if normal safety precautions are overlooked or ignored, personal injury to the operator may result. If you have any questions relative to the installation and operation, do not use the equipment until you have contacted your supplying distributor.**

**Read carefully before operating the machine.**

- 1. Keep the working area clean and be sure adequate lighting is available.**
- 2. Do not wear loose clothing, gloves, bracelets, necklaces or ornaments. Wear face, eye, respiratory and body protection devices as indicated for the operation or environment.**
- 3. Be sure that the power is disconnected from the machine before tools are serviced or an attachment is to be fitted or removed.**
- 4. Never leave the machine with the power on.**
- 5. Do not use dull, gummy or cracked cutting tools.**
- 6. Be sure that the keys and adjusting wrenches have been removed and all the nuts and bolts are secured.**

# Limited Warranty

New machines and accessories sold by Laguna Tools carry a one-year warranty effective from the date of shipping. Machines sold through dealers must be registered with Laguna Tools within 30 days of purchase to be covered by this warranty. Laguna Tools guarantees all new machines and accessories sold to be free of manufacturers' defective workmanship, parts and materials. We will repair or replace, without charge, any parts determined by Laguna Tools, Inc. to be a manufacturer's defect. We require that the defective item/part be returned to Laguna Tools with the complaint. Any machines returned to Laguna Tools must be returned with packaging in the same manner in which it was received. If a part or blade is being returned it must have adequate packaging to ensure no damage is received during shipping. In the event the item/part is determined to be damaged due to lack of maintenance, cleaning or misuse/abuse, the customer will be responsible for the cost to replace the item/part, plus all related shipping charges. This limited warranty does not apply to natural disasters, acts of terrorism, normal wear and tear, product failure due to lack of maintenance or cleaning, damage caused by accident, neglect, lack of or inadequate dust collection, misuse/abuse or damage caused where repair or alterations have been made or attempted by others.

Laguna Tools, Inc. is not responsible for additional tools or modifications sold or performed (other than from/by Laguna Tools, Inc.) on any Laguna Tools, Inc. machine. Warranty maybe voided upon the addition of such described tools and/or modifications, determined on a case-by-case basis.

Software purchased through Laguna Tools Inc. is not covered under this warranty and all technical support must be managed through the software provider. Software is non-refundable.

Normal user alignment, adjustment, tuning and machine settings are not covered by this warranty. It is the responsibility of the user to understand basic machinery operation, settings and procedures and to properly maintain the equipment in accordance with the standards provided by the manufacturer.

Parts, under warranty, are shipped at Laguna Tools, Inc.'s cost either by common carrier, FEDEX ground service or a similar method. Technical support to install replacement parts is primarily provided by phone, fax, e-mail or Laguna Tools Customer Support Website. The labor required to install replacement parts is the responsibility of the user.

Laguna Tools is not responsible for damage or loss caused by a freight company or other circumstances not in our control. All claims for loss or damaged goods must be notified to Laguna Tools within twenty-four hours of delivery. Please contact our Customer Service Department for more information.

Only **new** machines sold to the original owner are covered by this warranty. For warranty repair information, **call 1-800-332-4094**.



# INDEX

GENERAL SAFETY RULES -----	1
SPECIFIC SAFETY RULES -----	2
BEFORE OPERATION -----	3
INSTALLATION -	
STEP 1. MOVING THE MACHINE -----	4
STEP 2. CLEANING THE MACHINE -----	4
STEP 3. POWER WIRE CONNECTIONS -----	4
STEP 4. AIR CIRCUIT CONNECTION -----	5
STEP 5. DUST HOOD CONNECTION -----	5
STEP 6. INSTALL SANDING BELT -----	6
MAJOR PARTS OF THE MACHINE -----	7
BRAKE SYSTEM -----	8
CONTROL PANEL FEATURES -----	9
OPERATION OF DIGITAL PANEL -----	10
TABLE MOVEMENT -----	10
TROUBLE SHOOTING FOR DIGITAL CONTROL PANEL -----	11
ADJUSTMENT -	
SANDING BELT TENSION -----	12
SANDING BELT TRACKING -----	12
SANDING PLATEN POSITION -----	13
SANDING BELT OSCILLATION SPEED -----	13
V-BELT TENSION ADJUSTMENT -----	14
CONVEYOR BELT -----	14
FEED SPEED -----	15
PRESSURE ROLLER -----	15
TROUBLE SHOOTING -----	16
LUBRICATION AND MAINTENANCE -----	16
WIRE DIAGRAM -----	17
PARTS EXPLODED VIEW -----	18-37



## GENERAL SAFETY RULES

---

**READ THE MANUAL:** Read, understand and follow the safety and operating instructions found in this manual. Know the limitations and hazards associated with the Wide Belt Sander.

**WORK AREA:** Keep the floor around the machine clean and free of scrap material, sawdust, oil or grease to minimize the danger of tripping or slipping. Mark off the machine area, make sure it is well lighted, and includes a proper exhaust system to minimize dust.

**ELECTRICAL GROUNDING:** Your machine must be electrically grounded. If a cord and plug are used, make sure the plug connects to a suitable ground. Follow the grounding procedure indicated by the National Electrical Code. Keep power tools in dry areas free from moisture.

**PROTECTION:** Take every precaution to protect yourself, others around you, and the machine itself from improper use.

**CARELESS ACTS:** Give the work you are doing your complete, undivided attention. Horseplay, looking around, and talking to someone are careless acts that can result in serious injury. All children and visitors should be kept a safe distance from your work area.

**CHECK DAMAGED PARTS:** Before continuing use of the machine, a guard or other part that is damaged should be carefully checked to ensure that it will operate properly and safely and perform its intended function. Check for alignment of moving parts, binding of moving part, breakage of parts mounting and any other conditions that could effect its operation. A guard or other part that is damaged should be properly repaired or replaced before machine operation continues.



## GENERAL SAFETY RULES

---

**DO NOT OVER-REACH:** Maintain a balanced distance and keep your body under control at all times. Do not over-reach or use excessive force to perform any machine operation.

**EYES:** Always wear approved safety goggles, glasses or a face shield when operating the sander. There are no exceptions to this rule.

**DRESS CODES:** This machine can cause injury by catching loose clothing, jewelry, hair and gloves. Do not wear anything loose such as clothing, neckties, jewelry or gloves that can get caught in moving parts. Confine long hair, avoid wearing rings and watches, and keep sleeves above the elbow while operating this machine.

**HOUSEKEEPING:** Before turning on machine, remove all extra equipment such as keys, wrenches, scrap and cleaning rags away from the sander. Keep the area around the machine clean and free of sawdust to minimize danger of slipping.

**POWER ON:** Before connecting power to the sander, make sure the start switch is in the "OFF" position.

**POWER OFF:** Make sure the sander is unplugged or electrically disconnected and locked out before performing maintenance, checking belts or service work.



## SPECIFIC SAFETY RULES

---

**READ THE MANUAL:** Do not operate the wide belt sander until you read, understand and are able to follow the safety instructions found in this manual. Know what the wide belt sander can safely do, and what it can not do. Safety rules and caution decals are placed on the machines as reminders of good safety practices.

**HAND SAFETY:** Keep hands clear while feeding parts onto the conveyor table. The part will be forced down as it begins to feed into the machine, causing a pinching action between the part and the table. Use caution! Hands should be clear of the stock and the table to avoid pinching.

**PROTECT YOURSELF:** Protect yourself at all times when operating the wide belt sander. Avoid eye injury by wearing approved safety shields, goggles or glasses at all times. Wear protected footwear. Steel toed shoes are recommended because heavy parts can fall off the conveyor table onto feet.

**KEEP GUARDS IN PLACE:** Do not operate the sander with guards off. Keep the guards in place at all times when the machine is running. If removed for maintenance purposes or any other reason, use extreme caution and replace the guards upon completion of the task and before using the machine again. Injury can result from exposure to the machine's internal moving parts.

**NEVER REACH :** Never reach into a running machine. Turn off electrical power and stop machine before attempting to retrieve parts from within the machine. Contact with internal moving parts can result in loss or injury to fingers, hands and arms.

**DO NOT LEAVE UNATTENDED:** The operator of the sander is responsible for shutting the machine down when it is not in use.

**CAUTION:** The abrasive belt will coast to a stop in normal conditions, and will only break to a stop when the emergency devices are pressed!

**IT IS DANGEROUS TO LEAVE A MACHINE.**



## SPECIFIC SAFETY RULES

---

**UNATTENDED.** Person not familiar with the sander's operation could injure themselves or others.

**OPERATION POSITION:** Stand to one side of the conveyor table and make sure no one else is standing in line with the table while feeding into the machine. The wide belts sander operates at a high speed and should a part slip it will exit the machine at a high rate of speed and may result in injuries to anyone standing directly in front of the infeed. (Keep conveyor belt clean and check pin-roll adjustments)

**WORKING MATERIAL:** Do not attempt to sand working piece shorter than 9" (229mm) long without butting a board of equal thickness behind it to help stock through the machine. Boards less than 9" long can not be held secure enough for safe operation of this machine.

**MAINTAIN TOOLS:** Keep all tools sharp and clean for the best and safest performance and follow instructions for lubricating and changing accessories. Never stand on the machine. Serious injury could occur if the sander is tipped or if the sanding belt is accidentally contacted.

**DISCONNECT POWER:** Make sure sander is unplugged before performing maintenance or adjustments.

**IF YOU ARE NOT** thoroughly familiar with the operation of wide belt sander obtain device from your supervisor or other qualified person.

**DRUGS,ALCOHOL, MEDICATION:** Do not operate tool while under the influence of drugs, alcohol or any medication.

**WARNING:** The dust generated by certain woods and wood products can be dangerous to your health. Always operate machinery in well ventilated areas and provide for proper dust removal. Use wood dust collection systems whenever possible.



## BEFORE OPERATION

---

Before operating sander, make sure that :

1. Dust collection system is turned on.
2. Sanding belt specification is correct
3. Sanding belt is running in proper direction
4. Sanding belt tension is correct
5. All screws and handles are tightened securely.
6. Working air pressure is correct, normal working pressure is 4-5 kg/cm<sup>2</sup>  
Do not operate sander until normal pressure is reached.
7. Sanding belt is tracking correctly
8. Conveyor belt is tracking correctly
9. Thickness is correctly set
10. Feed speed is correctly set



## INSTALLATION-

### STEP 1. MOVING THE MACHINE

The machine should be moved to the work site with a fork lift. Make sure that the fork lift's loading capacity is adequate for the machine's weight. The forks must protrude from the far side of the machine bottom when moving. Pay careful attention to the machine balance while it is being moved, and make sure it does not strike the floor when being placed at the work site.

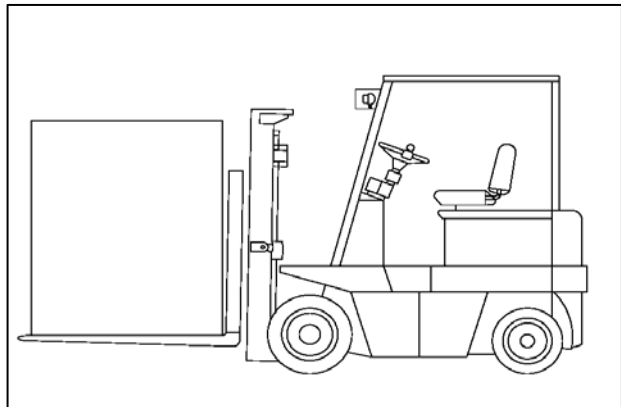

### STEP 2. CLEANING THE MACHINE

Anti-corrosive oil is applied to the machine before shipment. After unpacking, using a cloth soaked in kerosene to clean the anti-corrosive oil from the machine. Do not use lacquer thinner or any volatile solvents, as they can damage the surface of the machine.

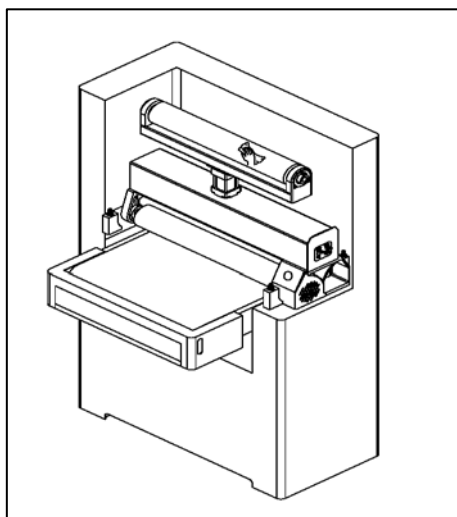

### STEP 3. POWER WIRE CONNECTIONS

Before connecting the power wires of the machine to the power supply, make sure the voltage, hertz, phase and amperage are compatible. The prewired voltage of the machine is indicated on the electrical indication plate.

The power source connection points are located inside the control box and are marked R.S.T. for 3-phase and R.S. for 1-phase. The ground wire connection point is marked "E". See Figure 1.

Once the wiring is completed, turn the machine on, press the conveyor table raising switch and see if the table moves the same direction indicated on the switch, if it does not, turn the machine off and switch any two of the three power source wires.

#### WARNING !!

ELECTRICAL WIRING SHOULD BE DONE BY A QUALIFIED ELECTRICIAN. THE MACHINE MUST BE PROPERLY GROUNDED TO HELP AVOID ELECTRIC SHOCK AND ASSOCIATED HAZARDS INCLUDING POSSIBLE DEATH.

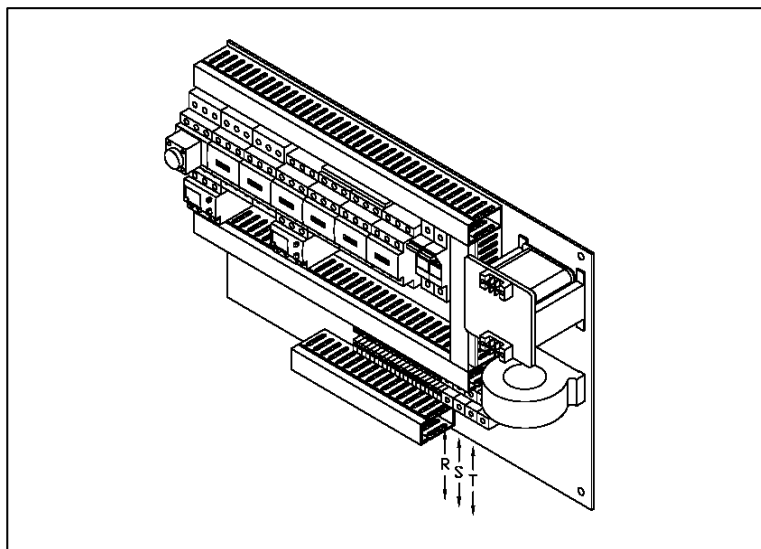

## STEP 4. AIR CIRCUIT CONNECTION

The air circuit connector is on the Filter/Regulator unit located on the back side of sander. Connect your air supply to the 5/16" air source connector with a flexible hose. The working pressure of the machine can be adjusted from the pressure regulator. Set the pressure by lifting the adjustment knob and rotate it clockwise to increase pressure, counter-clockwise to decrease pressure. When the correct pressure is set, push the knob down to lock it in place. See Figure 2. The recommended working pressure is 4-5 kg/cm<sup>2</sup>

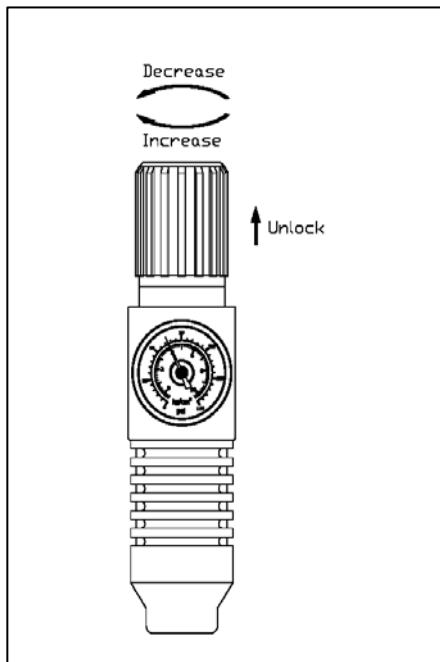
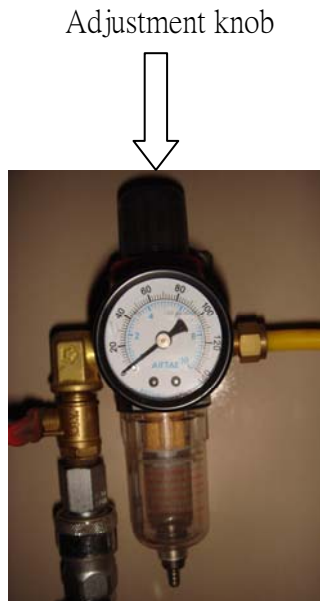

Figure 2

## STEP 5. DUST HOOD CONNECTION

Connect your dust collection system to the machine's dust hood (located on top) with a 4" diameter. Make sure the dust collector has sufficient capacity for the machine. See Figure 3

### NOTICE:

ALWAYS TURN ON THE DUST COLLECTOR BEFORE OPERATING THE SANDER.

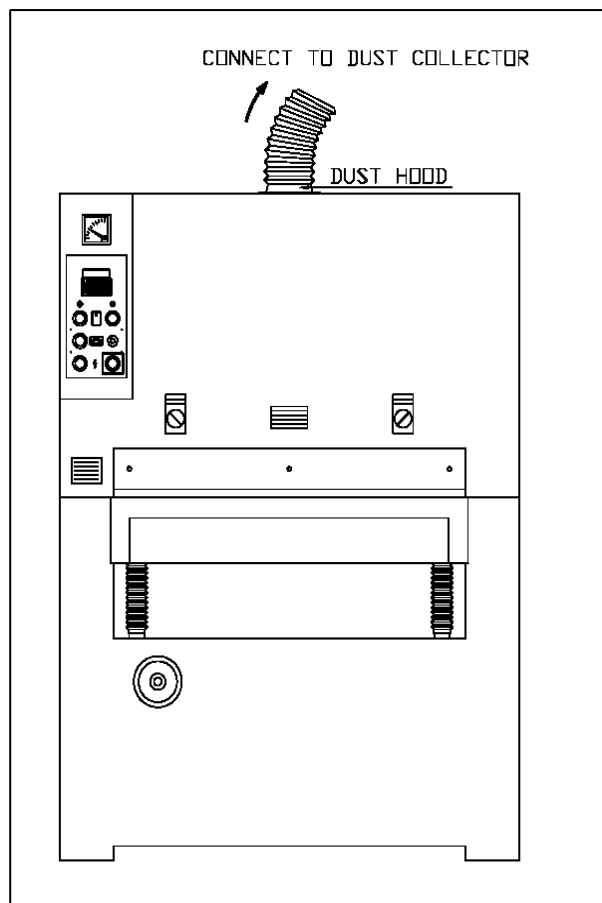

Figure 3

## INSTALL SANDING BELT

1. Disconnect machine from power source
2. Shut "OFF" the air tension switch ( C ).
3. Remove the pad lock lever ( D ) by turning it counterclockwise.
4. Remove the pad block ( E )
5. Remove the old belt by sliding it out the end  
( See Figure 4 )

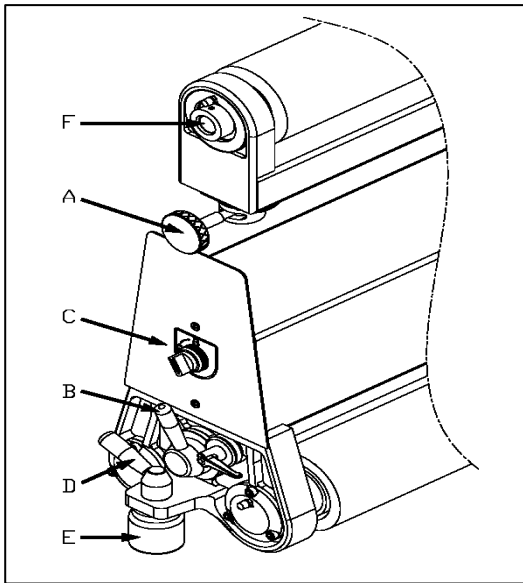

Figure 4 - PLATEN TYPE

## INSTALL SANDING BELT

6. Insert new belt by starting first on the upper roller ( F ), then the lower roller. Center the belt while avoiding contact with limit switch fingers that are located on each side of the belt.

**NOTICE !!**

Make sure the direction of the arrows on the inside of the belt matches the rotation of the machine. Check that the edges of the sanding belt are not chipped or torn.

7. Replace pad block ( E ) and tighten pad lock lever ( D ).
8. Turn "ON" the air tension switch ( C )
9. Make sure there is clearance between the belt edges and limit switch fingers on either side. If there is not, make the appropriate belt corrections according to the procedure above ( with the air tension turned off ) as necessary.

**NOTICE !!**

Machine will not start if a limit switch is depressed.

# MAJOR PARTS OF THE MACHINE --

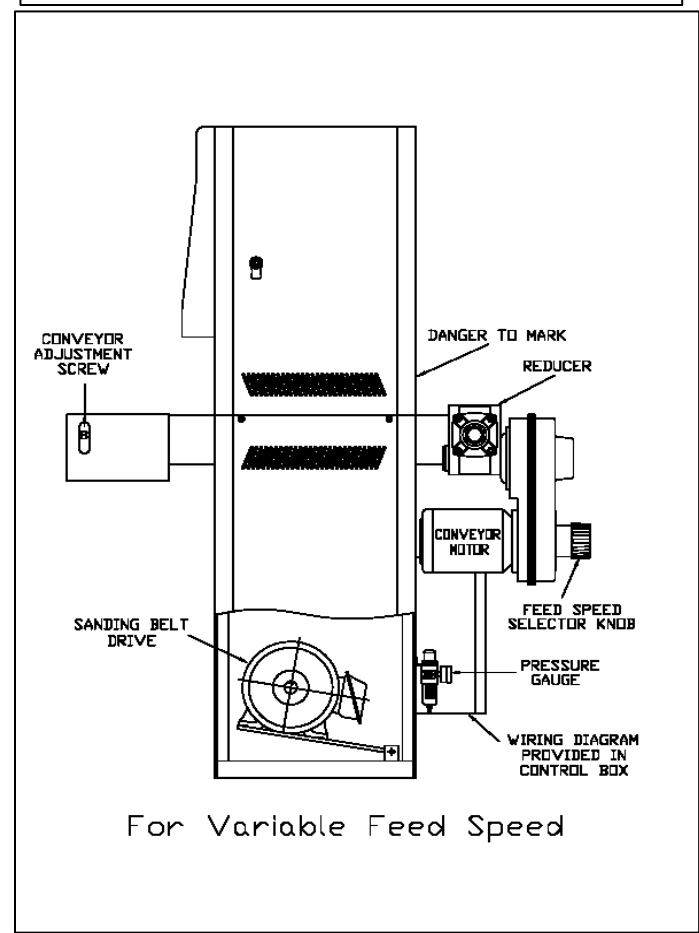
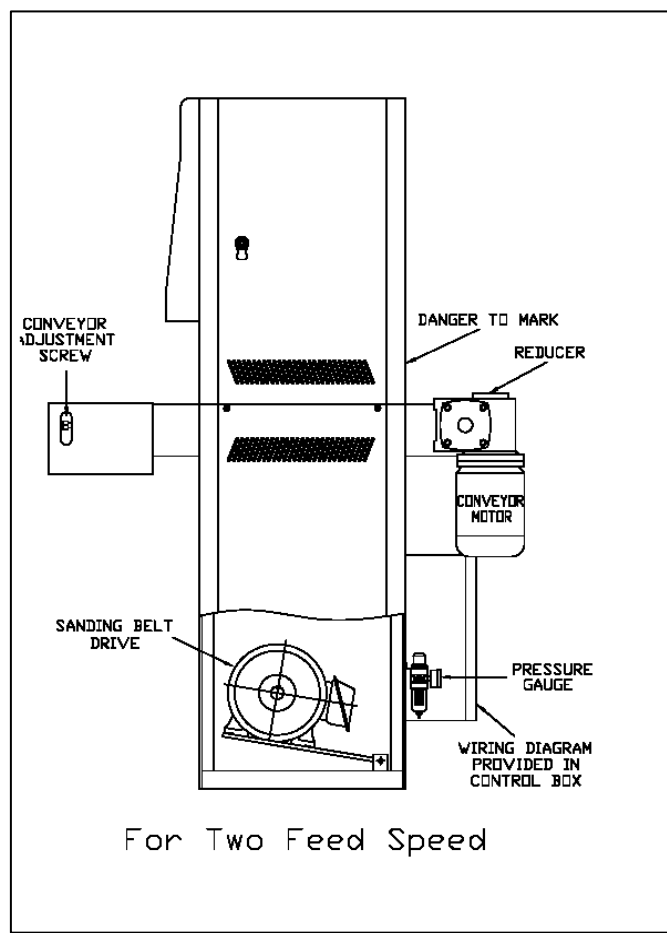
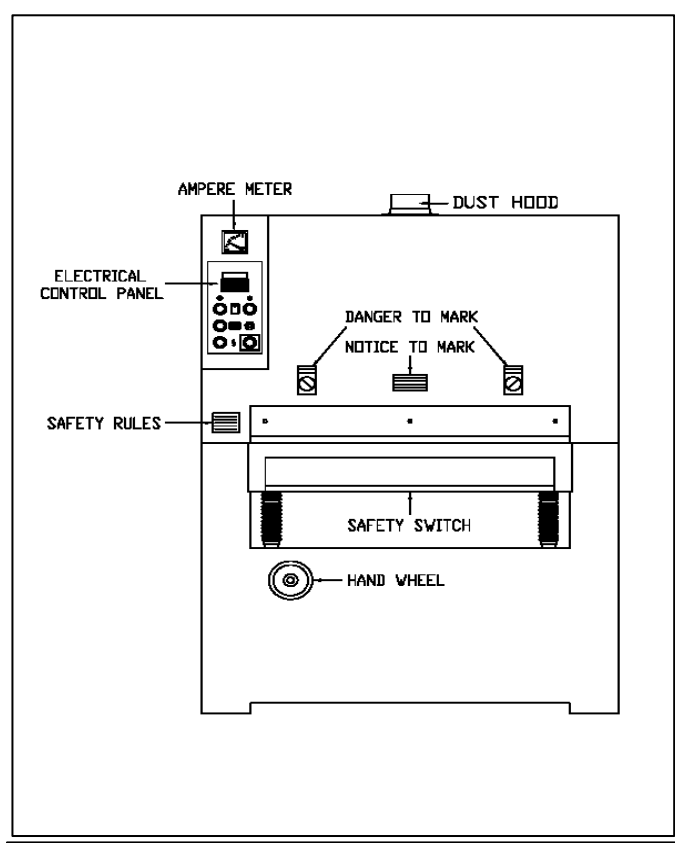

# BRAKE SYSTEM

The sander will stop automatically if any of the follow occur -

1. No air supply to the machine
2. No sanding belt mounted
3. Improper belt tension
4. Sanding belt rubs out of track
5. If the sanding belt breaks, all movement will be stopped, through the conveyor table can still be raised or lowered.
6. Once the machine has stopped, the operator should find where the braking sustem was tripped, and make the necessary adjustments. The machine can then be reset and restarted.

See **Figure 5.** for the location of limit switches.

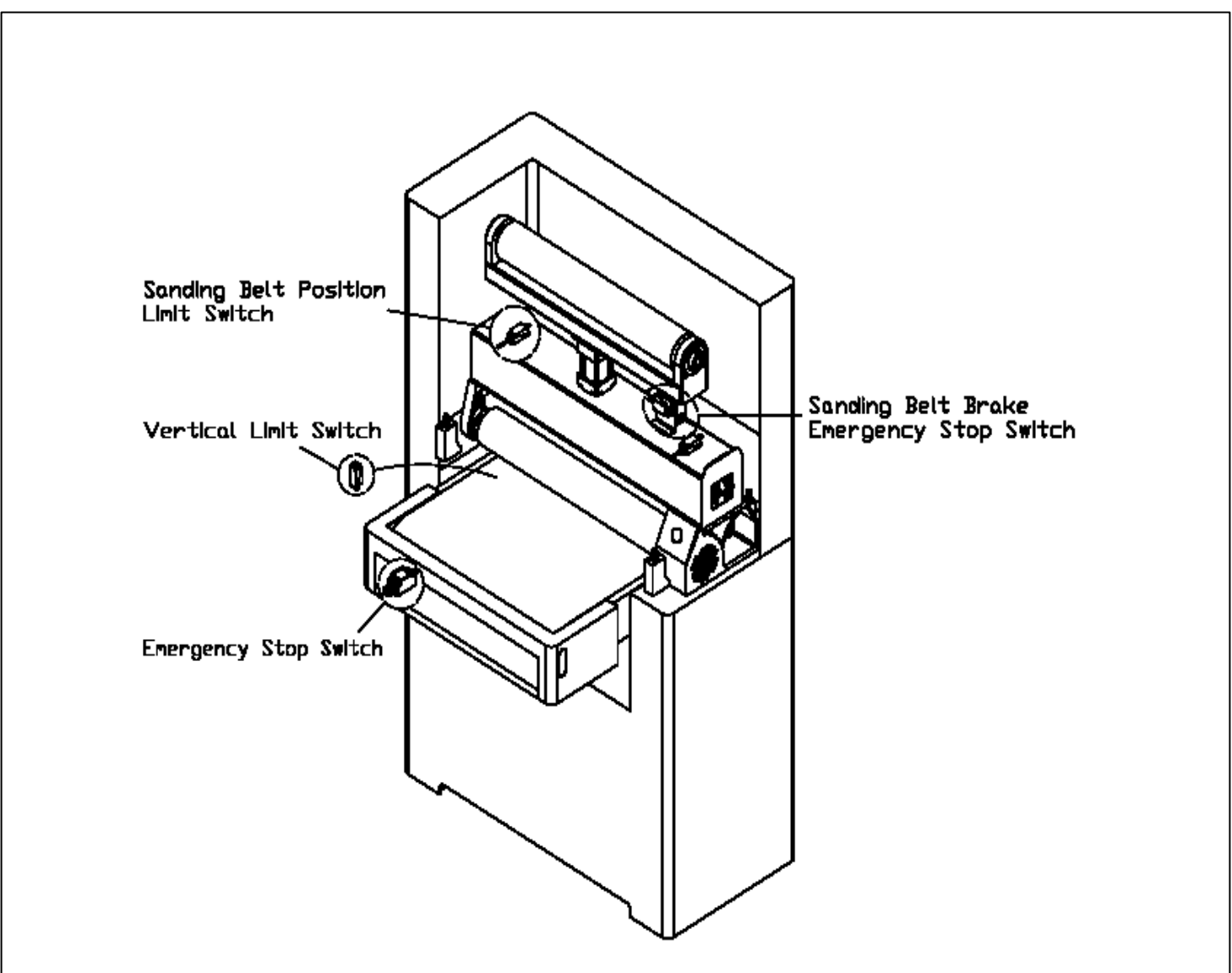

Figure 5

# CONTROL PANEL FEATURES

Figure 6

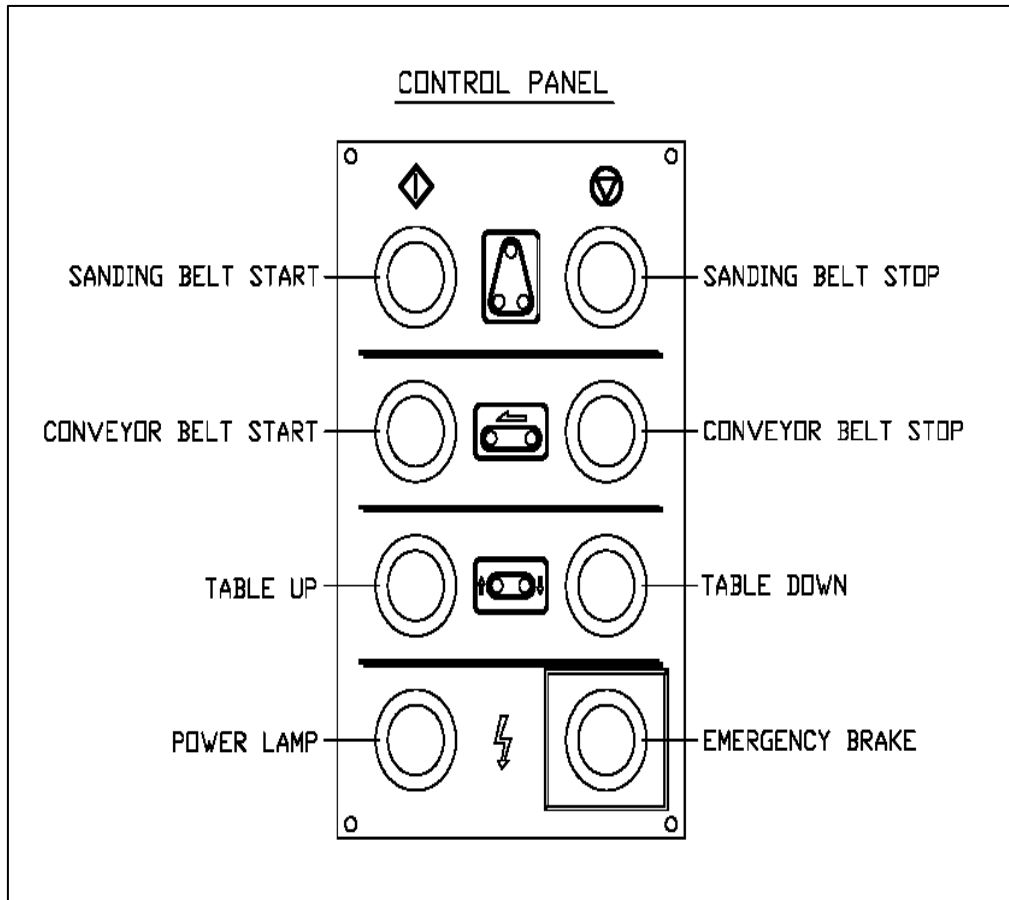
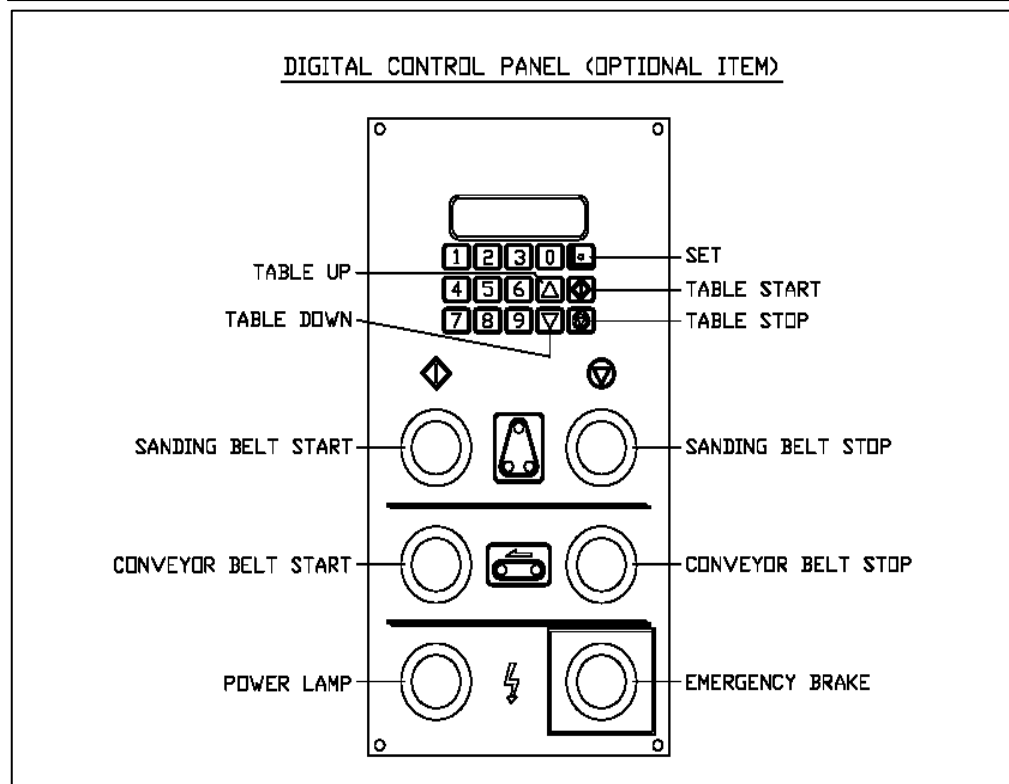

Figure 7



## OPERATION OF DIGITAL PANEL

### **CALIBRATION:**

1. Calibrate the digital readout by first measuring the thickness of your workpiece.
2. Input the correct figure to match the workpiece thickness and press "SET" for 2-5 seconds.

### **INPUT OF DATA:**

1. Press any of the number buttons and "000.0" will appear on the display.
2. Input the correct figure with the number buttons, then press "SET" for 2-3 seconds.
3. The display will begin flashing and then stop, with the new data on the display.
4. Alternatively, you may set the new input by pressing the + or- buttons until the proper figure is reached. NOTE: The INPUT and RUN lights will be illuminated at the same time.
5. Press "START"(The INPUT and RUN lights will be illuminated at the same time). The control unit will begin to run and the figure on the display will change back to 0, then it will start to increase up to the figures that were inputted.

### **MAGNIFICATION SETTING:**

1. This control unit can multiply the number of Encoder signals, 1,2 or 4 times to increase the resolution.
2. Turn off the power.
3. Select the function of x 1, x2 or x4 with the switch on the rear of the control unit.
4. Turn on the power.

## TABLE MOVEMENT

Table height can be adjusted manually or with the digital key pad.  
**See Figure 7**

### **MANUAL TABLE MOVEMENT:**

Turn the handwheel located under the front of the infeed table for manual table positioning.

### **MOTORIZED TABLE MOVEMENT:**

Press the TABLE UP or TABLE DOWN key once for motorized table positioning in 0.005" (0.1mm) increments.

### **NUMERICAL KEY PAD:**

Enter the position of sand depth.

### **METRIC OR STANDARD KEY:**

Press and hold the SET button for 3 seconds to calibrate display at the current board thickness; or press and hold key for 10 seconds to toggle the display between metric and standard measurement.

### **TABLE START:**

Moves table to a preset sanding depth

### **TABLE STOP:**

Stops table movement immediately

### **DIGITAL DISPLAY:**

Show final table sanding depth.

## TROUBLE SHOOTING FOR DIGITAL PANEL:

PROBLEM		POSSIBLE CAUSE		SOLUTION
The display fails to show figures		<ol style="list-style-type: none"> <li>1. Electric pressure of the 220V or AC110V is abnormal</li> <li>2. Fuse is burned out</li> <li>3. Control unit is out of order</li> </ol>		<ol style="list-style-type: none"> <li>1. Re-input correct electric pressure</li> <li>2. Replace 1A fuse</li> <li>3. Unit must be repaired or replaced by authorized service personnel</li> </ol>
Display shows abnormal figures		<ol style="list-style-type: none"> <li>1. Wrong figures were input</li> <li>2. Parameter is incorrect</li> </ol>		<ol style="list-style-type: none"> <li>1. Input the proper numbers in accordance with the actual dimensions</li> <li>2. Calculate correct parameter and input it</li> </ol> <p>*If the above steps are ineffective, turn the power off and then on. If it is still not working properly, it should be repaired or replaced.</p>
Display shows figures, but they do not change in conjunction with the hoist motor's operation.		<ol style="list-style-type: none"> <li>1. Proximity switch is not functioning (a functioning proximity switch will cause the light on the induction switch to be illuminated or put out depending on movement of the table)</li> <li>2. Distance between induction unit and induction sheet is more than 2mm.</li> <li>3. Encoder not running in accordance with the table movement. Axle connector off or damaged.</li> <li>4. Use Watt-hour meter to measure if phase A.B. matches the change of DC12V and 0V. If phase A.B. has no change, encoder is defective.</li> </ol>		<ol style="list-style-type: none"> <li>1. Change proximity switch</li> <li>2. Adjust distance between induction unit and induction sheet to less than 1 mm</li> <li>3. Repair or replace Encoder</li> <li>4. Replace Encoder</li> </ol>
Travel dimension incorrect		<ol style="list-style-type: none"> <li>1. Control unit parameter is not in harmony with the table</li> </ol>		<ol style="list-style-type: none"> <li>1. Connect control unit parameter</li> </ol>



## ADJUSTMENT --

### SANDING BELT TENSION

The tension of sanding belt is controlled by an air cylinder. Turn the tension air switch to tightened or loosen the sanding belt tension.

When the machine is not in use, release the sanding belt tension to avoid sanding belt fatigue.

"A" - Tracking Adjustment Lever

"C" - Air Tension Switch

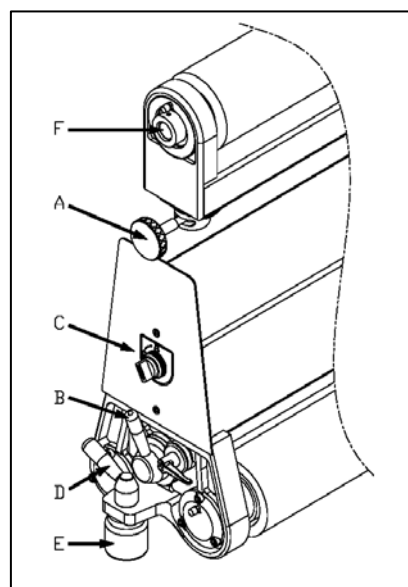
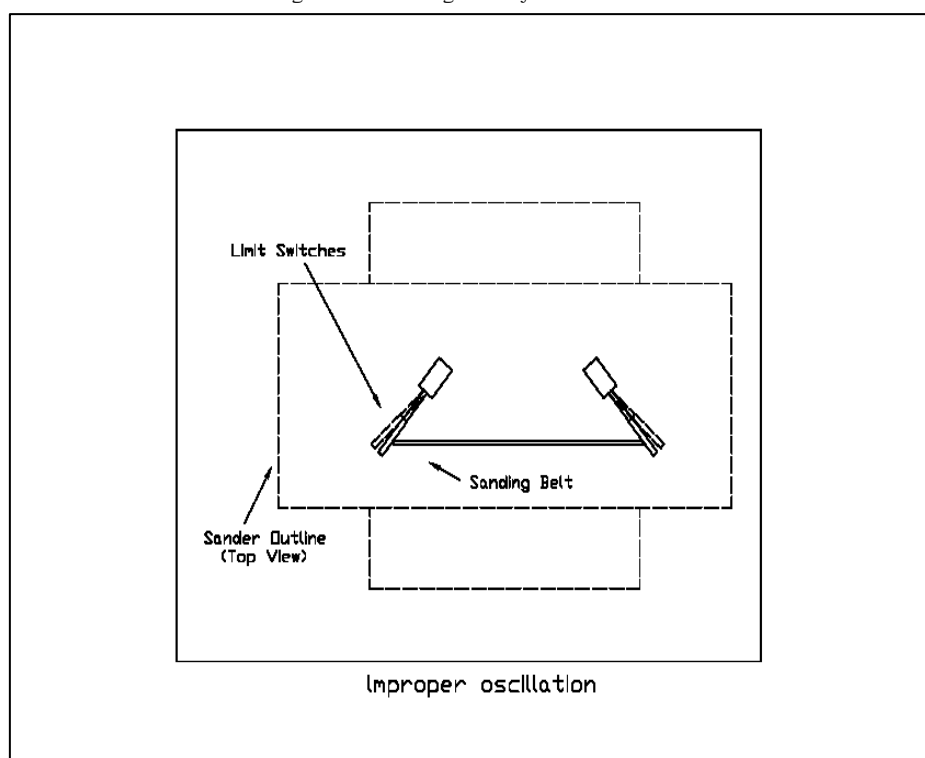

Figure 8

### SANDING BELT TRACKING

If the sanding belt runs outside of the normal track, the machine will stop automatically. When replacing the sanding belt, there may be a length tolerance between the right and left sides of the belt which may result in the incorrect tracking of the sanding belt. If this occurs, it will be necessary to adjust the tracking:

1. The degree of sanding belt oscillation to the right side and to the left should be equal. For example, if the oscillation time to the right is one second, then the oscillation time to the left is one second.
2. If the oscillation time to the right is one second, but the oscillation time to the left is longer, then loosen the tracking adjustment lever. See Figure 8 and move it to the left until proper tracking is achieved. When satisfied, tighten the lever.
3. If the oscillation time to left is one second, but the oscillation time to the right is longer, then loosen the tracking adjustment lever and move it to the right until proper tracking is achieved. Tighten adjustment lever.



## SANDING PLATEN POSITION

### ( FOR THE ROLLER WITH PLATEN ONLY)

The sanding platen is constructed of graphite cloth and felt.

It is applied for polishing or fine finishing operations with about 0.1mm sanding load. But it is not suitable for neavy sanding operations.

Positioning of the platen depends upon the type of wood being used.

Adjust the platen position with the platen adjustment knob, **see Figure 9**

Turn it clockwise to lower the platen, counter-clockwise to raise it. Each revolution of the knob is 0.2mm.

### NOTICE !!

THE PLATEN SHOULD ALWAYS BE KEPT CLEAN.

AFTER SANDING IF THE WORKPIECE HAS STRAIGHT NOTCHES ACROSS IT, THE GRAPHITE CLOTH AND FELT HAVE WORN OUT AND SHOULD BE REPLACE IMMEDIATELY.

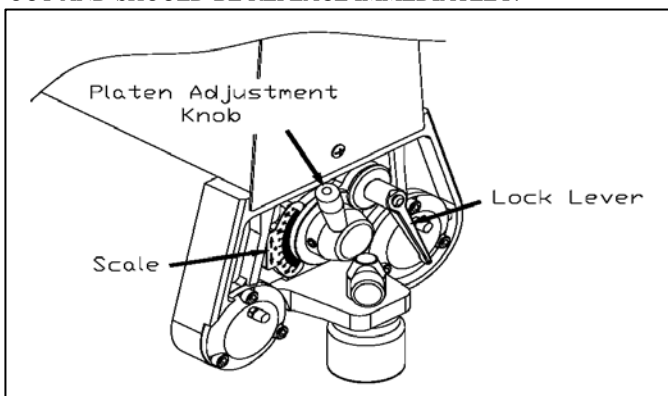
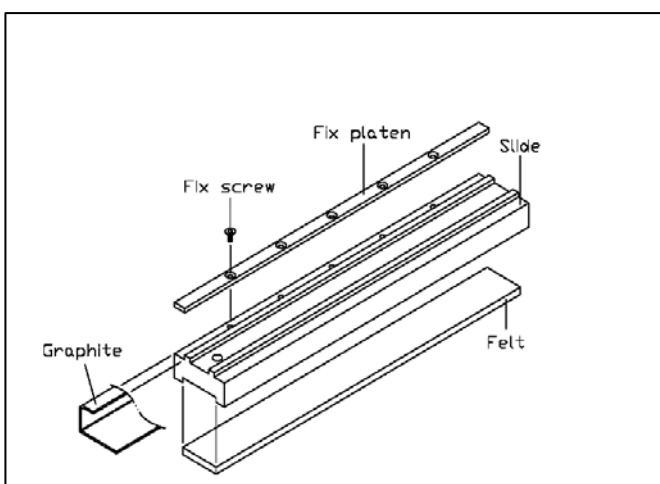

Figure 9



## SANDING BELT OSCILLATION SPEED

The sanding belt oscillation is controlled by the air cylinder.

Oscillation speed can be adjusted by means of the speed controller on the cylinder, **see Figure 10**.

Loosen the fixing nut on the speed controller, then turn controller clockwise to decrease oscillation speed. Turn counter-clockwise to increase oscillation speed.

The hole in the air eye should be checked frequently. If it becomes blocked with dust, it may casue the sanding belts to run out of its normal track and the mahcine will shut off. In the event of blackage, this hole should be cleaned.

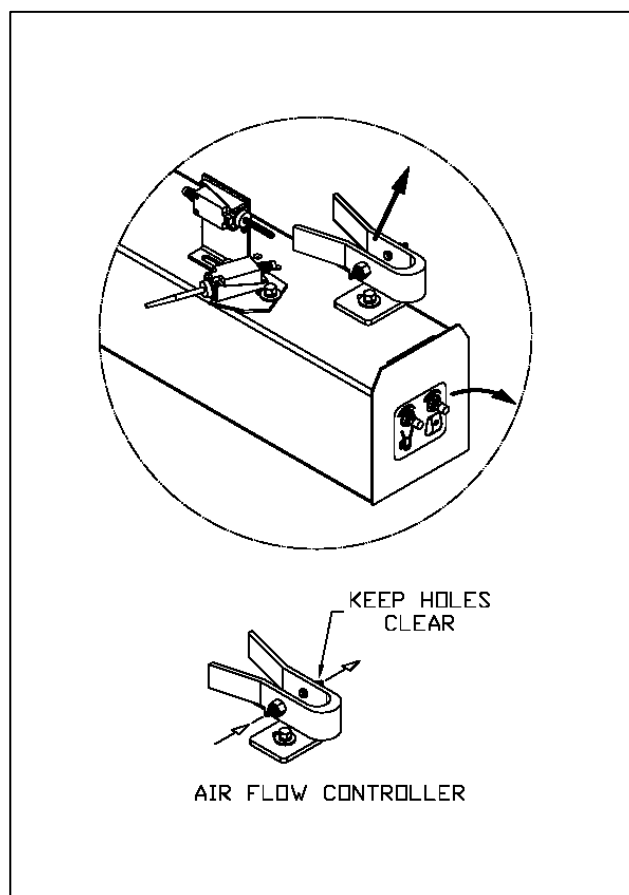

Figure 10

## V-BELT TENSION ADJUSTMENT

After the machine has been in operation for a long time, the V-belt may become slightly loose. Should this occur, there will be an abnormal sound while the motor is running. Adjust the V-belt as follow.

**Figure 11:** Slightly loose the lock unit that tightens the motor base, and turn the adjustment screw until correct tension is achieved.

Re-tightened lock nut.

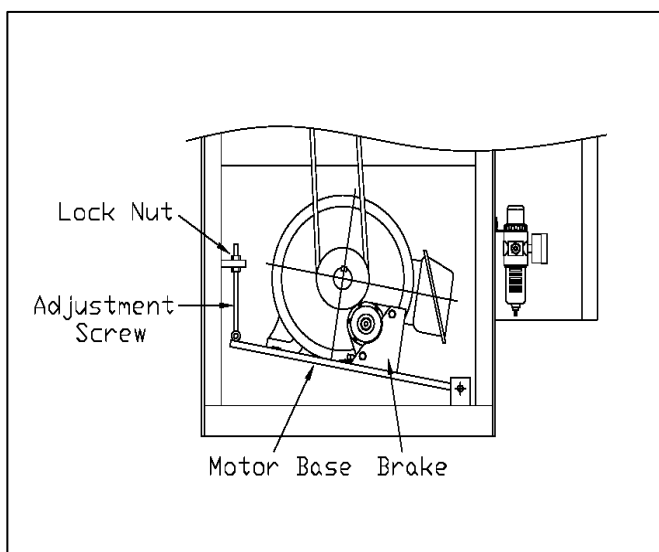

Figure 11

## CONVEYOR BELT

The conveyor belt should always run at the center of the contact drum. If it approaches either to the left or right, adjustment is necessary. First check that the conveyor belt tension is correct. If the tension is too loose, adjust this first before you adjust the tracking.

See Figure 12

### CONVEYOR BELT TENSION:

1. Disconnect the sander from the power source.
2. Remove from brake cover by removing the four screw.
3. Turn both adjustment rod clockwise equally to increase tension.

### CONVEYOR BELT TRACKING:

1. Turn the conveyor belt "ON"
2. If the belt is tracking to the **right** side of the table, turn the **right** adjustment rod clockwise.
3. If the belt is tracking to the **left** side of the table, turn the **left** adjustment rod clockwise.

**NOTICE !!**

THE EDGE OF THE CONVEYOR BELT SHOULD JUST TOUCH THE GUIDE WHEELS.

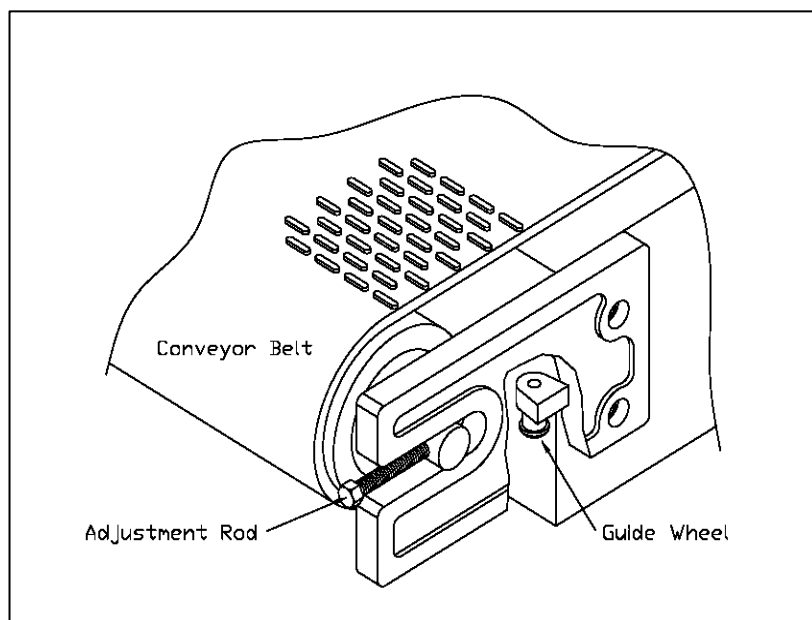

Figure 12

## FEED SPEED

### (FOR VARIABLE SPEED ONLY)

The feed speed adjustment is infinitely variable in order to meet the sanding requirements of a wide variety of materials. In general, soft woods require a higher feed speed, while hard woods require a lower feed speed.

However, correct feed speed selection is largely a matter of experience.

**CAUTION !!**

### CHANGE THE FEED SPEED ONLY WHILE THE MACHINE IS RUNNING.

Adjust the feed speed with the speed selector knob of the worm gear reducer. **Figure 13**, and the speed adjustment valve of the hydraulically driven conveyor belt. Turn the feed speed selector knob clockwise to decrease the conveyor belt speed, counter-clockwise to increase it.

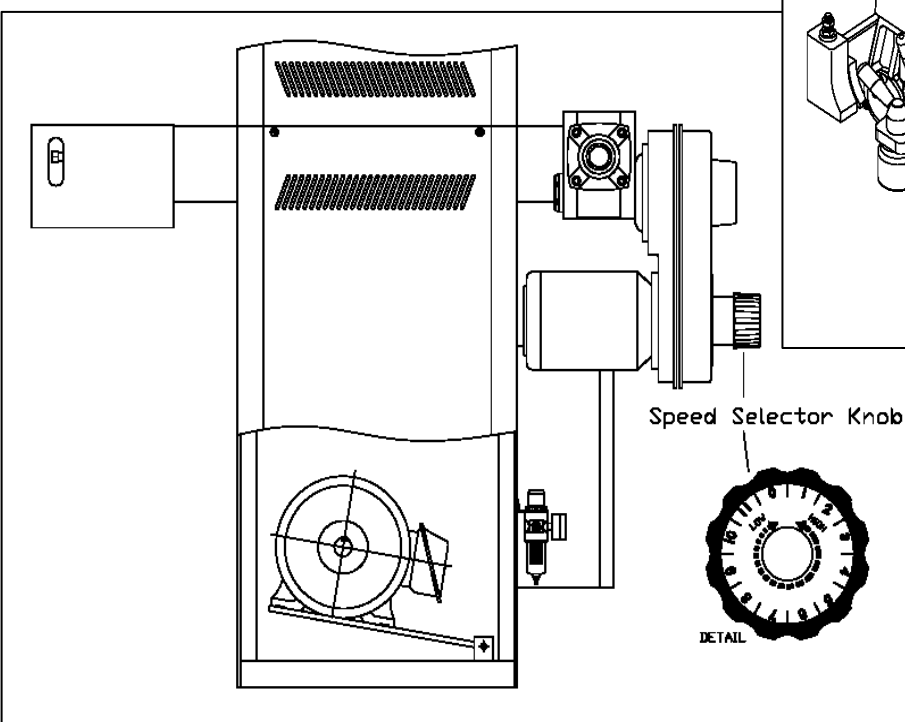

Figure 13

## PRESSURE ROLLER

The front and rear pressure rollers have been factory adjusted. However, if further adjustment is ever required, proceed as follows:

1. Stop machine
2. Place a sanded panel on the conveyor belt and under the rollers. The panel should be long enough to contact both front and rear rollers. Raise the table until panel contacts the rollers.
3. Make sure the pressure at the right and left side of pressure rollers is even
4. Loosen the fix nut then turn the adjustment knob as shown in **Figure 14**.
5. When parallelism is satisfactory, retighten the fix nut.

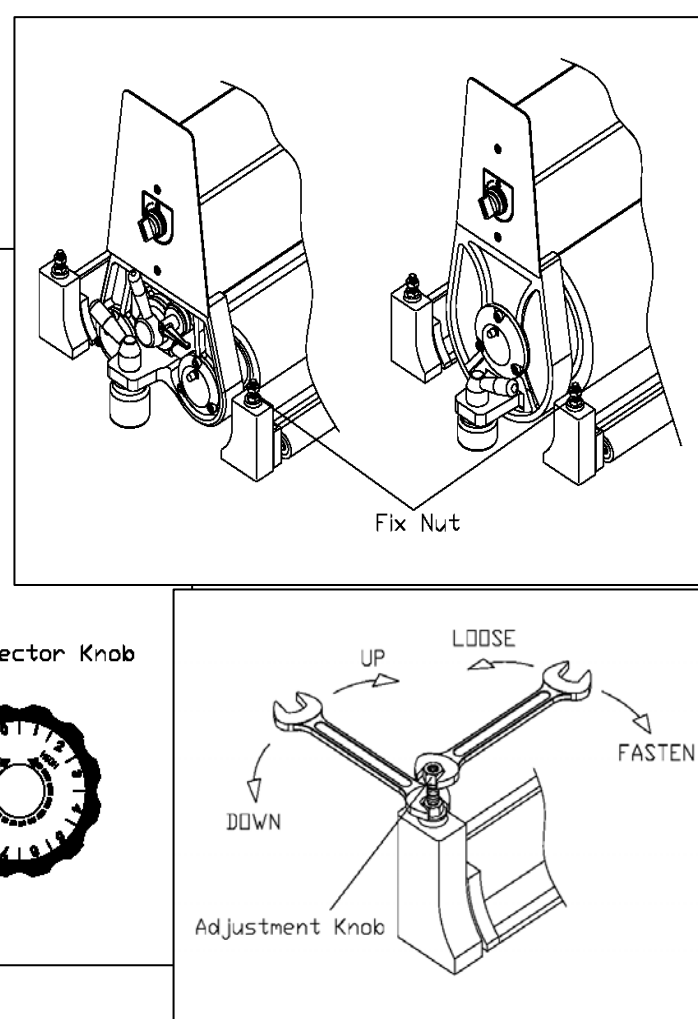

Figure 14

PROBLEM	POSSIBLE CAUSE	SOLUTION
Sanding belt clogs too quickly	<ol style="list-style-type: none"> <li>1. Grit of sanding belt is too fine</li> <li>2. Sanding overload</li> <li>3. Too much oil, dirt on wood surface</li> </ol>	<ol style="list-style-type: none"> <li>1. Replace with larger grit</li> <li>2. Reduce sanding load.</li> <li>3. Clean wood, or use better work</li> </ol>
Too many roundings created along the edge while sanding solid wood	<ol style="list-style-type: none"> <li>1. Too much material being removed</li> </ol>	<ol style="list-style-type: none"> <li>1. Reduce the amount of material being removed</li> </ol>
Uneven thickness between the left and right sides of the workpiece	<ol style="list-style-type: none"> <li>1. Conveyor table not parallel with contact roller</li> <li>2. Conveyor belt worn out</li> <li>3. Graphite cloth and carpet on the pad are worn out</li> </ol>	<ol style="list-style-type: none"> <li>1. Adjust conveyor table / contact roller to parallel</li> <li>2. Replace conveyor belt</li> <li>3. Replace graphite cloth and carpet</li> </ol>
Uneven thickness between the front and rear ends of the workpiece	<ol style="list-style-type: none"> <li>1. Feed speed too fast</li> <li>2. Sanding overload</li> <li>3. Grit of sanding belt too fine</li> <li>4. Unequal position of pressure plate</li> </ol>	<ol style="list-style-type: none"> <li>1. Reduce rate of feed</li> <li>2. Reduce sanding load</li> <li>3. Use large grit sanding belt</li> <li>4. Adjust pressure plate to produce equal pressure on stock</li> </ol>
Workpiece slips on the conveyor belt	<ol style="list-style-type: none"> <li>1. Too much pressure from pressure plate</li> <li>2. Dirty conveyor belt</li> <li>3. Conveyor belt is worn out</li> </ol>	<ol style="list-style-type: none"> <li>1. Reduce force from pressure plate</li> <li>2. Clean conveyor belt</li> <li>3. Replace conveyor belt</li> </ol>
Straight notches on workpiece surface	<ol style="list-style-type: none"> <li>1. Dirty pressure plate</li> <li>2. Contact drum is scratched</li> <li>3. Graphite cloth and carpet on the pad are worn out</li> </ol>	<ol style="list-style-type: none"> <li>1. Clean pressure plate</li> <li>2. Replace drum</li> <li>3. Replace cloth and carpet</li> </ol>
Snake markings on workpiece	<ol style="list-style-type: none"> <li>1. Sanding belt partially damaged</li> <li>2. Worm area on sanding belt</li> </ol>	<ol style="list-style-type: none"> <li>1. Repair/replace sanding belt</li> <li>2. Replace sanding belt</li> </ol>
Cross-parallel stripes across the entire width of workpiece	<ol style="list-style-type: none"> <li>1. Sanding belt joint is too thick</li> <li>2. Worn areas on sanding belt</li> <li>3. Sanding load not less than 0.0mm</li> </ol>	<ol style="list-style-type: none"> <li>1. Replace sanding belt</li> <li>2. Replace sanding belt</li> <li>3. Reduce sanding load to less than 0.0mm</li> </ol>

#### LUBRICATION AND MAINTENANCE:

1. The machine interior should be thoroughly cleaned every day after work. It is important to remember to remove the sanding belt before cleaning and replace it afterwards.
  2. The bearings should be greased after every 150 work hours.
  3. If the machine is equipped with a hydraulic power system, the hydraulic oil should be renewed after after every 6000 work hours.
  4. The water should be released from the filter cup regularly
  5. Make sure that there is an adequate oil film on the table jack screws (support screws) at all times.
  6. The oil inside the gear reducer should be changed after the first 300 hours of operation, and every 2500 hours of use thereafter.
- Recommended oil is #140 gear oil.

GENERAL ELECTRICAL DIAGRAM ( 37 1K - SINGLE PHASE)

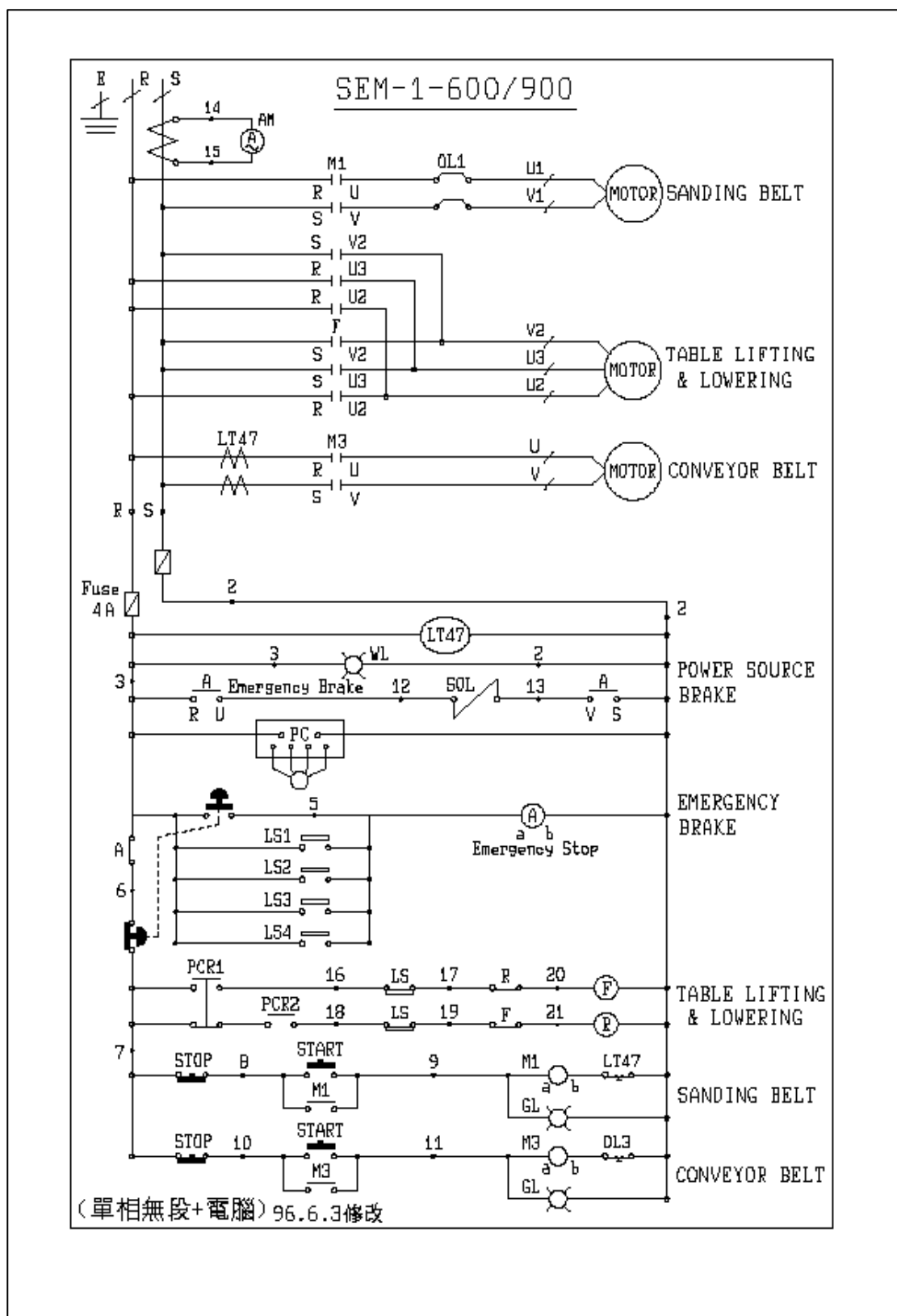

371K-0000

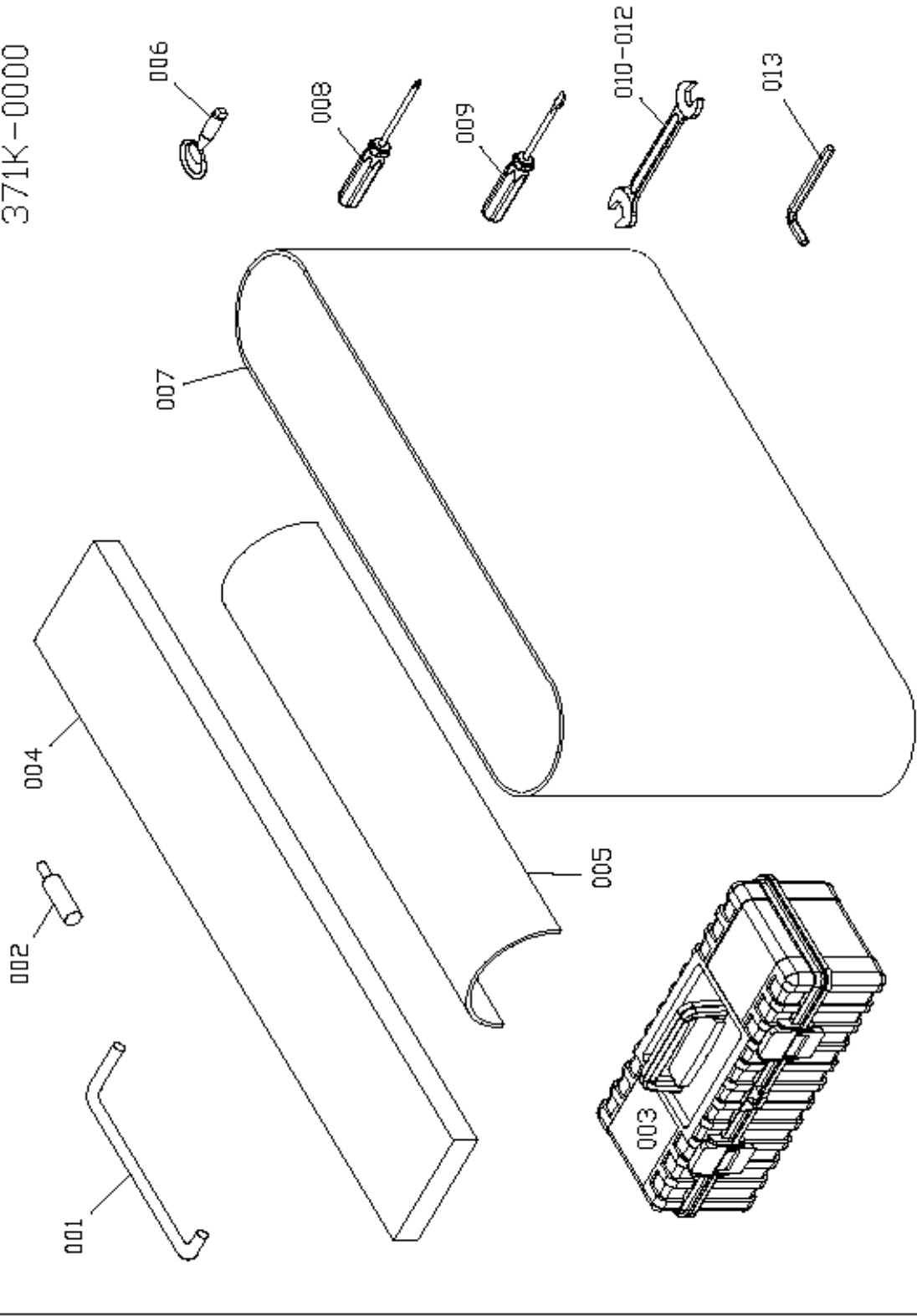

0000	
ITEM NO	DESCRIPTION
001	GRAPHITE HOLDER
002	LIMIT SWITCH TUBE
003	TOOL BOX
004	FELT
005	GRAPHITE
006	KEY
007-1	SANDING BELT #100
007-2	SANDING BELT #180
008	PHILLIP'S SCREWDRIVER
009	FLAT SCREW DRIVER
010	WRENCH 8 X 10
011	WRENCH 12 X 14
012	WRENCH 17 X 19
013	HEX WRENCH



371K-1000

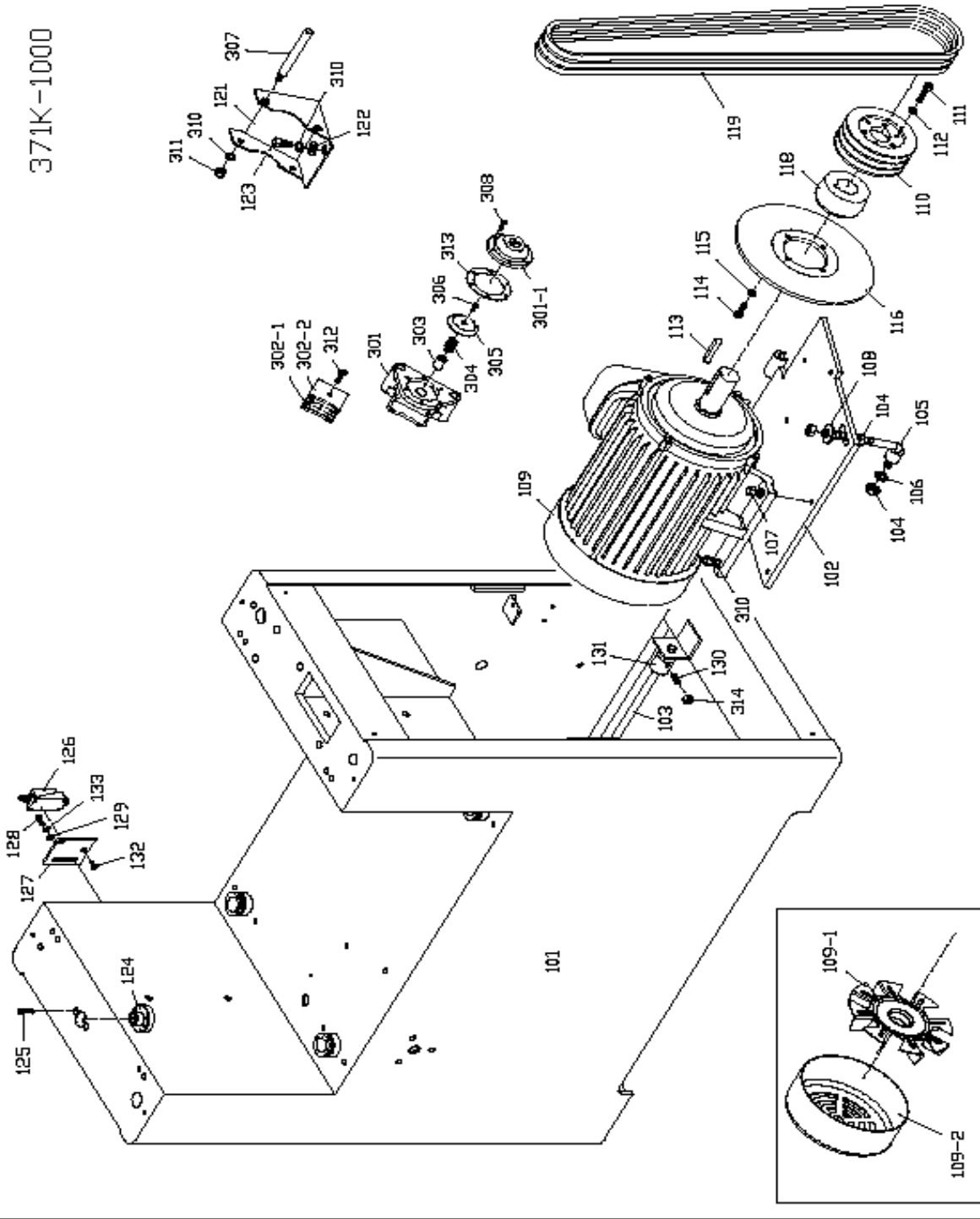

1000		1000	
ITEM NO	DESCRIPTION	ITEM NO	DESCRIPTION
101	MACHINE FRAME	126	LIMIT SWITCH
102	MOTOR BASE	127	LIMIT SWITCH PLATE
103	MOTOR BASE HINGE	128	SCREW 1/4" X 1/2"
104	NUT 1/2"	129	PLAIN WASHER 1/4"
105	MOTOR BASE ADJUSTMENT ROD	132	FLAT HEAD SCREW
106	SPRING WASHER 1/2"	133	SPRING WASHER
107	SCREW	301	BRAKE BRACKET
108	PLAIN WASHER 1/2"	301-1	BRAKE BRACKET FRONT GUARD
109	MOTOR	302-1	BRAKE LINING
109-1	FAN	302-2	BRAKE LINING
109-2	FA COVER	303	BRAKE ARBOR
110	PULLEY	304	BRAKE SPRING
111	HEX SOCKET HEAD SCREW 5/16" X 1 1/4"	305	BRAKE INSIDE PIECE
112	SPRING WASHER 5/16"	306	FLAT HEAD SCREW 1/4" X 1/2"
113	KEY	307	BRAKE PIN
114	SCREW 5/16" X 1"	308	HEX SOCKET HEAD SCREW
115	SPRING WASHER 5/16"	310	SPRING WASHER 3/8"
116	DISC BRAKE	311	NUT 3/8"
118	PULLEY BUSHING	312	HEX SOCKET HEAD SCREW 1/4" X 5/8"
119	BELT	313	BRAKE GASKET
121	BRAKE BRACKET		
122	PLAIN WASHER 3/8"		
123	SCREW 3/8" X 3/4"		
124	FLAT HEAD NUT		
125	HEX SOCKET HEAD SCREW 1/4" X 3/4"		

# 371K-2000

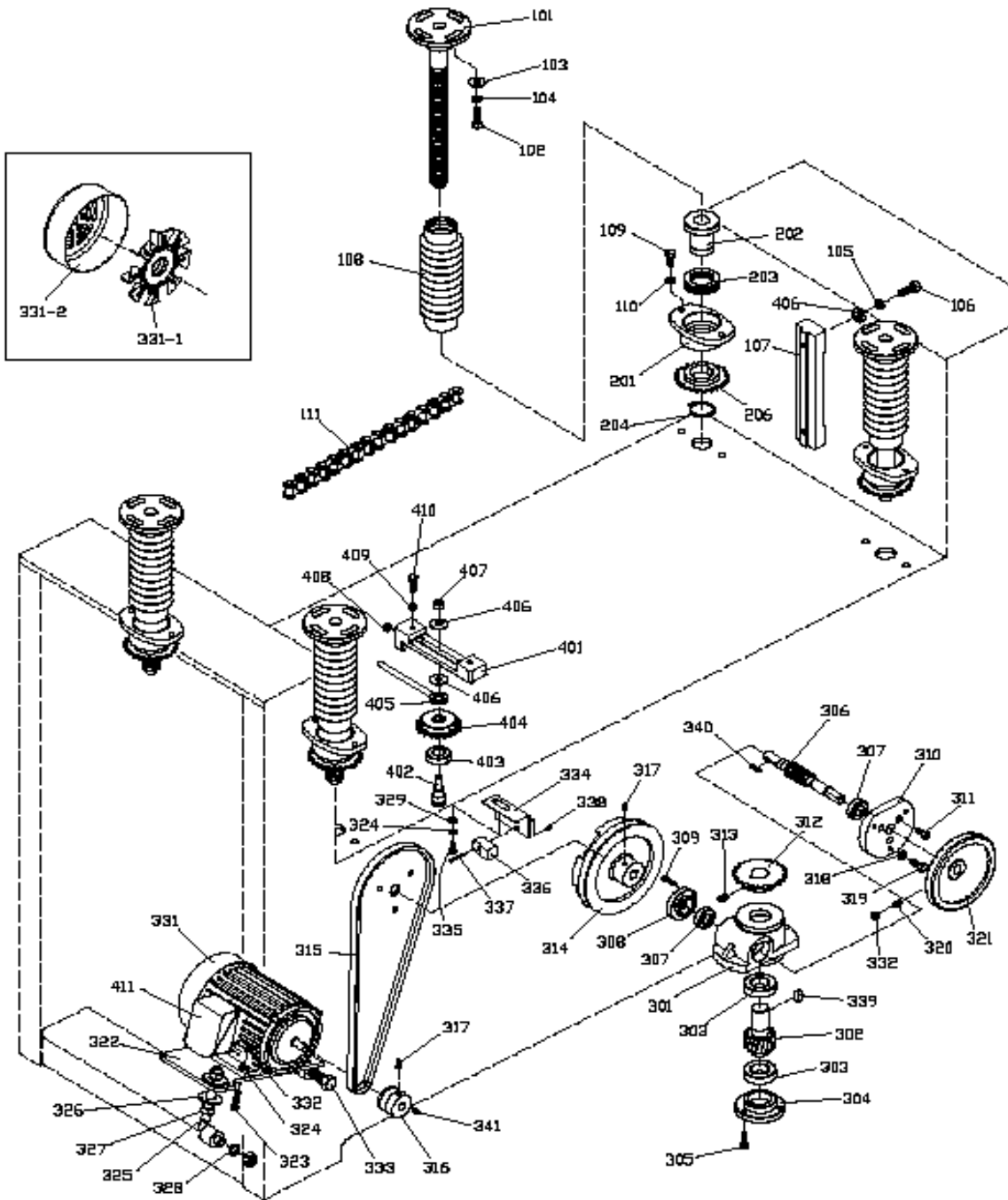

2000		2000	
ITEM NO	DESCRIPTION	ITEM NO	DESCRIPTION
101	ELEVATION SCREW	320	HEADLESS SCREW 1/4" X 1/2"
102	SCREW 5/16" X 1"	321	HAND WHEEL
103	PLAIN WASHER 5/16"	322	MOTOR BASE
104	SPRING WASHER 5/16"	323	SCREW 1/4" X 1"
105	SPRING WASHER 3/8"	324	SPRING WASHER 1/4"
106	SCREW 3/8" X 1"	325	MOTOR BASE ADJUSTMENT ROD
107	ELEVATION SLIDE	326	PLAIN WASHER 1/2"
108	DUST GUARD BELLOW	327	NUT 1/2"
109	SCREW 5/16" X 3/4"	328	SPRING WASHER 1/2"
110	SPRING WASHER 5/16"	331	MOTOR
111	CHAIN	332	NUT 1/4"
		333	SCREW 1/2" X 4 1/2" LONG
201	NUT HOUSING	334	PROXIMITY SWITCH FIXING PLATE
202	NUT	335	SCREW 1/4" X 1/2"
203	THRUST BEARING 51107	336	PROXIMITY SWITCH
204	"C" CIRCLIP S 35	337	ROUND PHILLIP'S SCREW M3 X 35MM
206	SPROCKET WHEEL	338	NUT M3
		339	KEY 5/16" X 20MM
301	ELEVATION GEAR BOX	340	KEY
302	WORM GEAR	341	KEY
303	BEARING 6005Z		
304	BEARING CAP	401	SPROCKET WHEEL ADJUSTMENT PIECE
305	HEX SOCKET HEAD SCREW 1/4" X 3/4"	402	SPROCKET WHEEL SHAFT
306	WORM SHAFT	403	BEARING 6003ZZ
307	BEARING 6002Z	404	ADJUSTMENT SPROCKET WHEEL
308	BEARING CAP	405	SPROCKET WHEEL ADJUSTMENT ROD
309	HEX SOCKET HEAD SCREW	406	PLAIN WASHER 3/8"
310	BEARING CAP	407	NUT 3/8"
311	HEX SOCKET HEAD SCREW 1/4" X 5/8"	408	NUT 5/16"
312	SPROCKET WHEEL	409	SPRING WASHER 5/16"
313	HEADLESS SCREW 5/16" X 1/2"	410	SCREW 5/16" X 3/4"
314	PULLEY		
315	BELT		
316	PULLEY		
317	HEADLESS SCREW 1/4" X 1/2"		
318	SPRING WASHER 5/16"		
319	SCREW 5/16" X 3/4"		

371K-3000

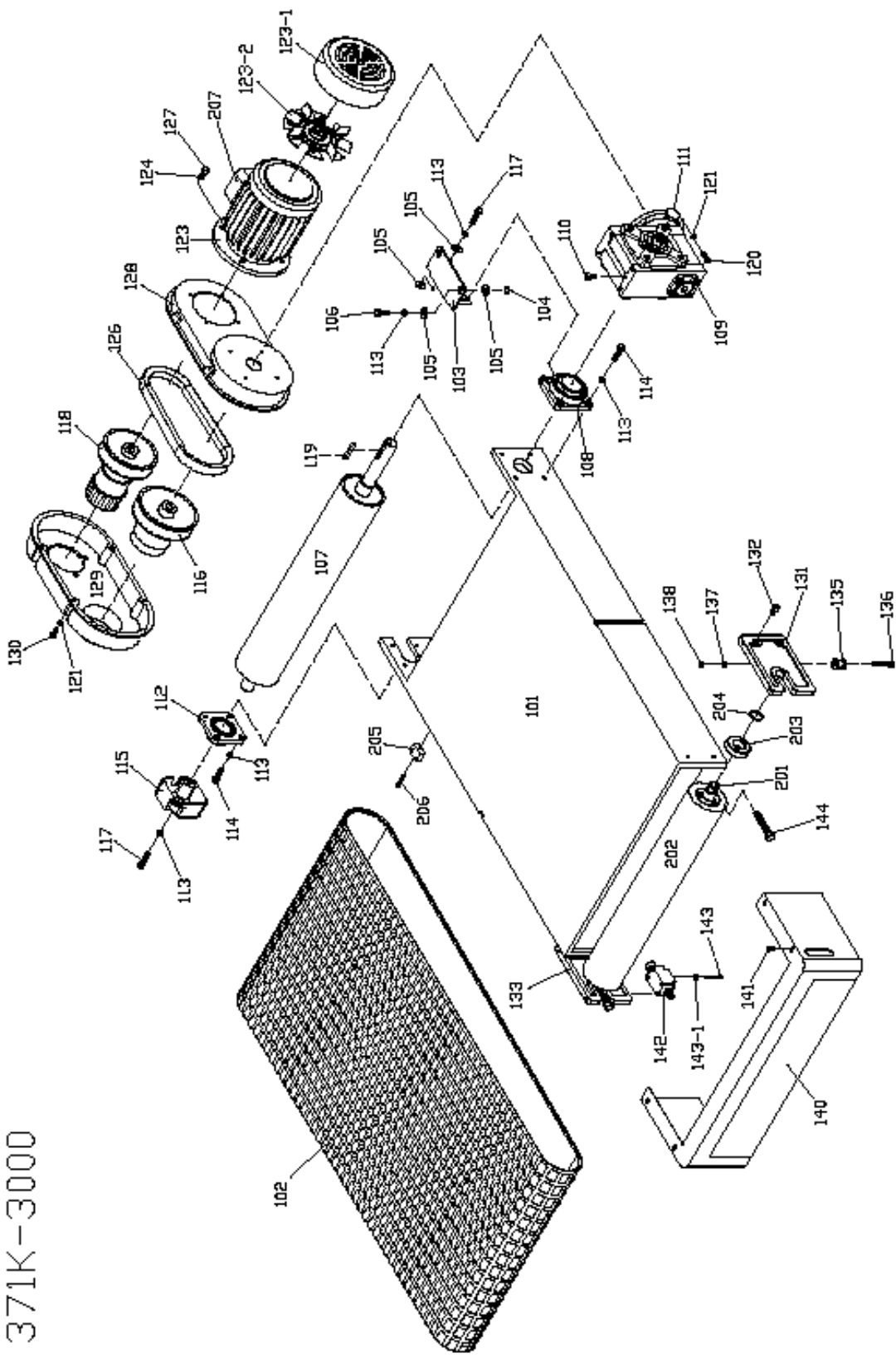

3000		3000	
ITEM NO	DESCRIPTION	ITEM NO	DESCRIPTION
101	CONVEYOR TABLE	142	LIMIT SWITCH
102	CONVEYOR BELT	143	ROUND PHILLIP'S SCREW
103	REDUCER FIX PLATE	144	SCREW 1/2" X 3" LONG
104	CUSHION		
105	PLAIN WASHER 3/8"	201	INFEED ROLLER SHAFT
106	SCREW 3/8" X 1"	202	INFEED ROLLER
107	OUTFEED ROLLER	203	BEARING
108	BEARING UCF 205	204	"C" CIRCLIP S30
109	REDUCER	205	ELEVATION ALUMINUM LIMITER
110	PLUG	206	HEX SOCKET HEAD SCREW
111	PLUG		
112	BRAING UCF 205		
113	SPRING WASHER 3/8"		
114	SCREW 3/8" X 1 1/4"		
115	BEARING CAP		
116	DRIVEN PULLEY		
117	SCREW 3/8" X 1 1/2"		
118	DRIVING PULLEY		
119	KEY 7MM X 55MM		
120	SCREW M8 X 25MM		
121	SPRING WASHER 8MM		
123	MOTOR		
124	SPRING WASHER 10MM		
126	TIMING BELT		
127	SCREW M10 X 25MM		
128	VARIABLE SPEED UNIT BASE PLATE		
129	VARIABLE SPEED UNIT COVER		
130	HEADLESS SCREW M8 X 20MM		
131	INFEED ROLLER BRACKET		
132	HEX SOCKET HEAD SCREW 3/8" X 3/4"		
133	INFEED ROLLER BRACKET		
135	CONVEYOR BELT POSITIONING WHEEL		
136	HEX SOCKET HEAD SCREW 5/16" X 2"		
137	SPRING WASHER 5/16"		
138	NUT 5/16"		
140	FRONT BRAKE COVER		
141	ROUND PHILLIP'S SCREW 1/4" X 1/2"		

371K-4000

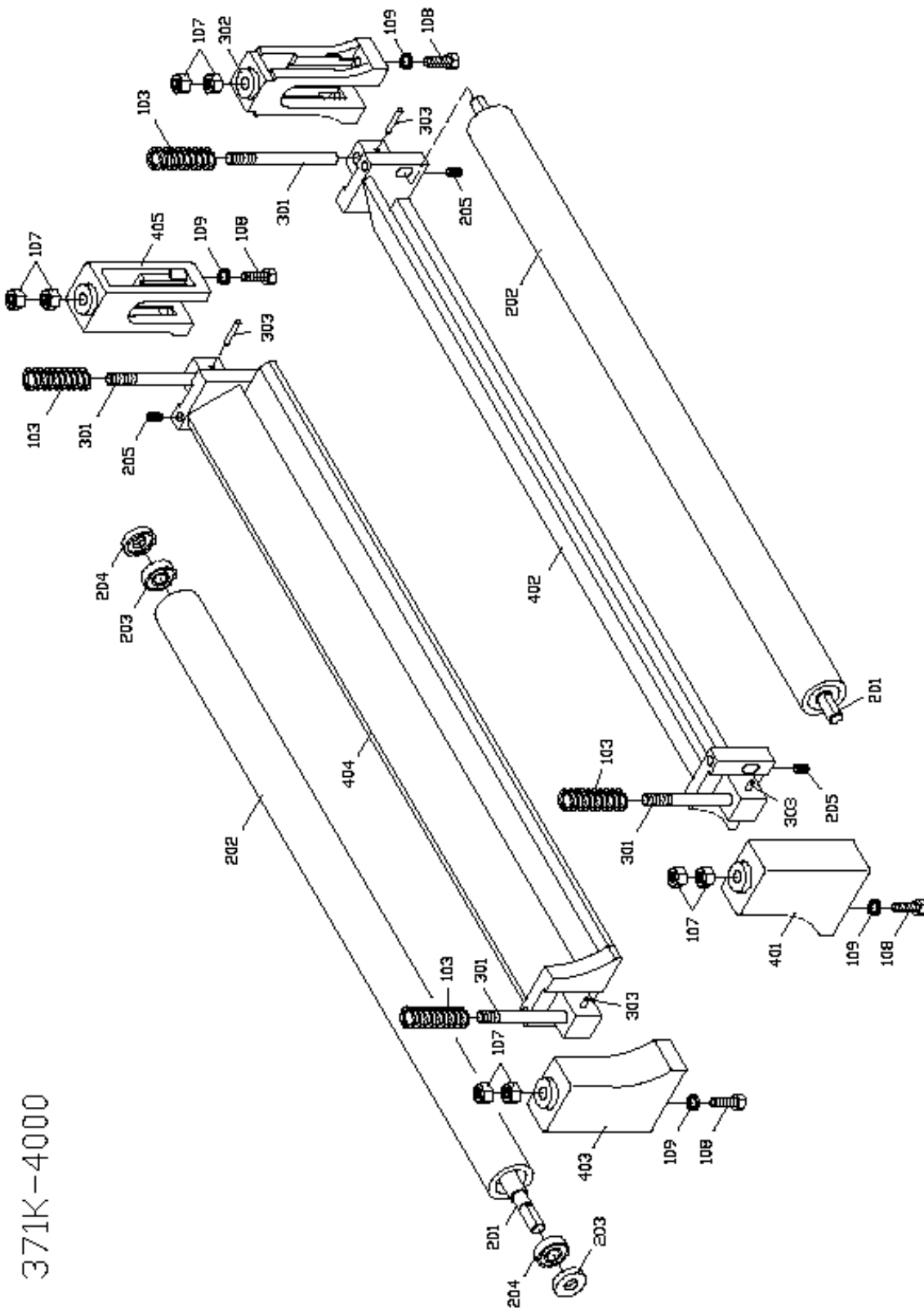

4000	
ITEM NO	DESCRIPTION
103	COMPRESSION SPRING
107	HEX NUT
108	HEX BOLT 5/16-18 X 1 1/4
109	LOCK WAHER 5/16"
201	PISTION ROLLER SHAFT
202	PISTON ROLLER
203	BEARING 6001ZZ
204	SHAFT BEARING COLLAR
205	SET SCREW
301	PISTION ROLLER ADJ.ROD
302	PISTON BRACKET
303	PIN 3 X 24 MM
401	PISTION BRACKET
402	PRESSURE SHOES
403	PISTON BRACKET
404	PRESSURE SHOES
405	PISTON BRACKET



371K-5000

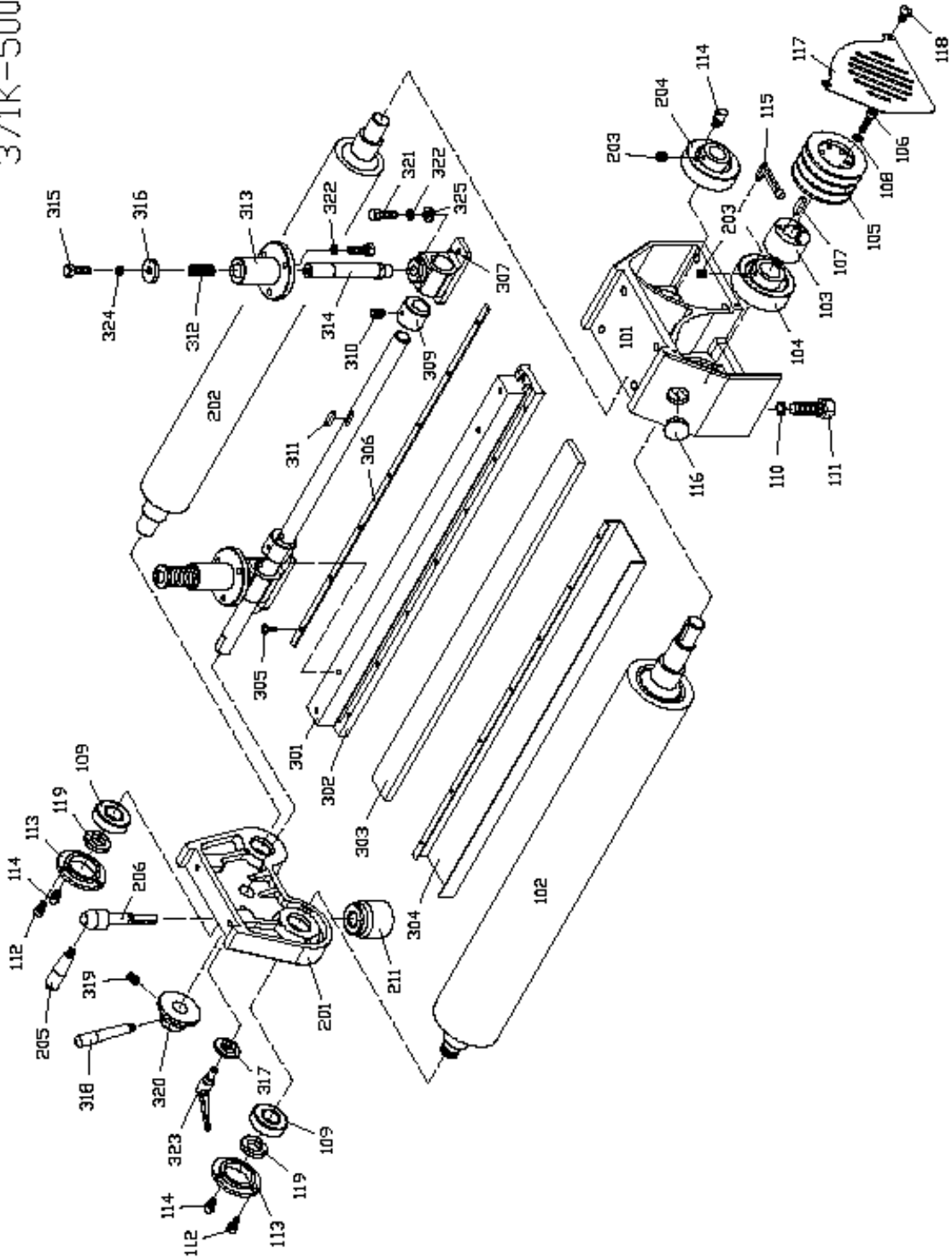

5000		5000	
ITEM NO	DESCRIPTION	ITEM NO	DESCRIPTION
101	BEARING HOSUING	309	FASTENING TUBE
102	RUBBER ROLLER	310	HEADLESS SCREW 1/4" X 3/8"
103	FASTENING TUBE	311	KEY 1/4" X 25MM
104	BEARING UCC206	312	SPRING
105	PULLEY	313	HOSUING OF FIXING SHAFT
106	HEX SOCKET HEAD SCREW 5/16" X 1 1/4"	314	FIXING SHAFT OF GRAPHITE BRACKET
107	KEY 5/16"	315	CAP 3/8" X 3/4"
108	SPRING WASHER 5/16"	316	PLAIN 3/8"
109	BEARING 6205-2RS	317	WASHER
110	SPRING WASHER 1/2"	318	HANDLE
111	HEX SOCKET HEAD SCREW 1/2" X 1 1/2"	319	HEADLESS SCREW 5/16" X 1/2"
112	HEX SOCKET HEAD SCREW 1/4" X 1/2"	320	RING FOR ADJUSTMENT
113	BEARING CAP	321	SCREW 5/16" X 1"
114/115	FILTER	322	PLAIN WASHER 5/16"
116	PLUG	323	HANDLE FOR FASTENING
117	COVER OF PULLEY		
118	SCREW		
119	SCREW CAP		
201	BEARING HOUSING		
202	STEEL ROLLER		
203	HEX SOCKET HEAD SCREW M6 X 6MM		
204	BEARING UCC 205		
205	HANDLE		
206	FLAT HEAD SCREW		
211	BEARING BRACKET PAD		
301	GRAPHITE BRACKET (MALE)		
302	GRAPHITE BRACKET (FEMALE)		
303	FELT		
304	GRAPHITE		
305	PHILLIP'S SCREW 3/16" X 1/2"		
306	GRAPHITE PRESSURE PLATE		
307	FIXING BASE OF GRAPHITE BRACKET		

371K-6000

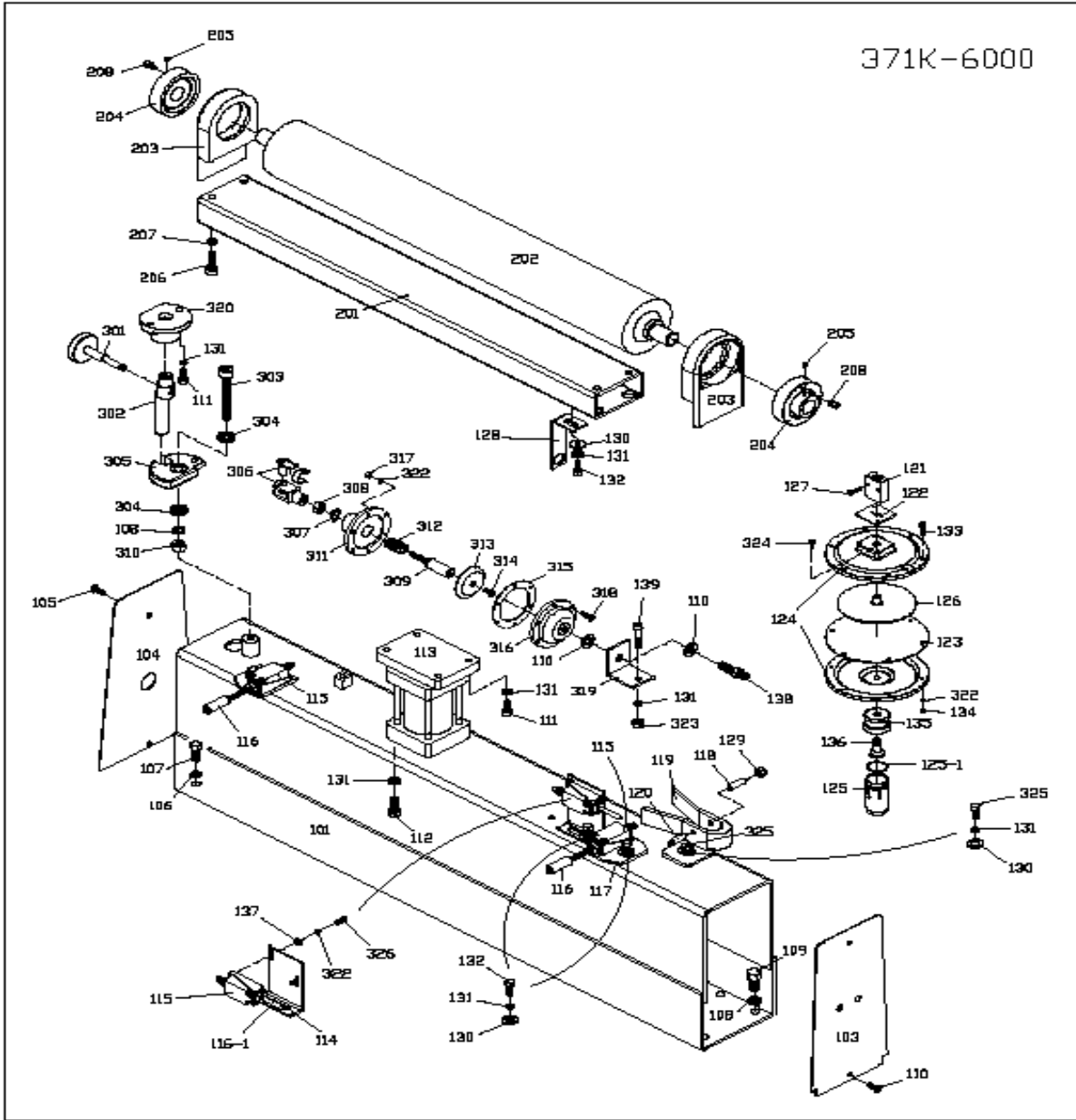

6000		6000	
ITEM NO	DESCRIPTION	ITEM NO	DESCRIPTION
101	SQUARE FRAME	201	UPPER ROLLER BRACKET
103	SQUARE FRAME SEAL (RIGHT)	202	UPPER ROLLER
104	SQUARE FRAME SEAL (LEFT)	203	UPPER ROLLER BRACKET
105	FLAT HEAD SCREW 1/4" X 1/2"	204	BEARING UCC205
106	SPRING WASHER 3/8"	205	HEADLESS SCREW M6 X 6MM
107	SCREW 3/8" X 1"	206	HEX SOCKET HEAD SCREW
108	SPRING WASHER 1/2"	207	SPRING WASHER 3/8"
109	SCREW 1/2" X 1"	208	FILTER
111	HEX SOCKET HEAD SCREW 5/16" X 3/4"		
112	SCREW M8 X 20MM	301	TRIMMING SCREW
113	AIR CYLINDER	302	ECCENTRIC ROD
114	LIMIT SWITCH HOLDER (L TYPE)	303	HEX SOCKET HEAD SCREW 1/2" X 3 1/2"
115	LIMIT SWITCH	304	PLAIN WASHER 1/2"
116	LIMIT SWITCH TUBE	305	ECCENTRIC PIECE
117	LIMIT SWITCH HOLDER	306	UNIVERSAL JOINT FORK
118	AIR SENSOR NOZZLE ( FEMALE )	307	"C" CIRCLIP S15
119	AIR CYLINDER BRACKET	308	NUT M10
120	AIR SENSOR NOZZLE (MALE)	309	SHAFT OF AIR CYLINDER
121	THROTTLE VALVE	310	NUT 1/2"
122	THROTTLE VALVE BASE	311	BOTTOM COVER
123	PLATE	312	SPRING
124	ALUMINUM DISC	313	ALUMINUM PLATE
125	OIL CAP	314	SCREW M6 X 12MM
126	ALUMINUM PLATE	315	PLATE
127	SCREW M4 X 20MM	316	TOP COVER
128	SANDING BELT POWER OFF PLATE	317	NUT 3/16"
129	NUT 3/8"	318	SCREW 3/16" X 3/4"
131	SPRING WASHER 5/16"	319	FIRING BASE OF AIR CYLINDER
132	SCREW 5/16" X 3/4"	320	FRAME OF ECCENTRIC SHAFT
133	SCREW 3/16" X 3/4"		
134	NUT 3/16"		
135	CONNECTOR OF OIL CAP		
136	SHAFT OF OIL CAP		
139	HEX SOCKET HEAD SCREW 5/16" X 1 1/2"		

371K-7000

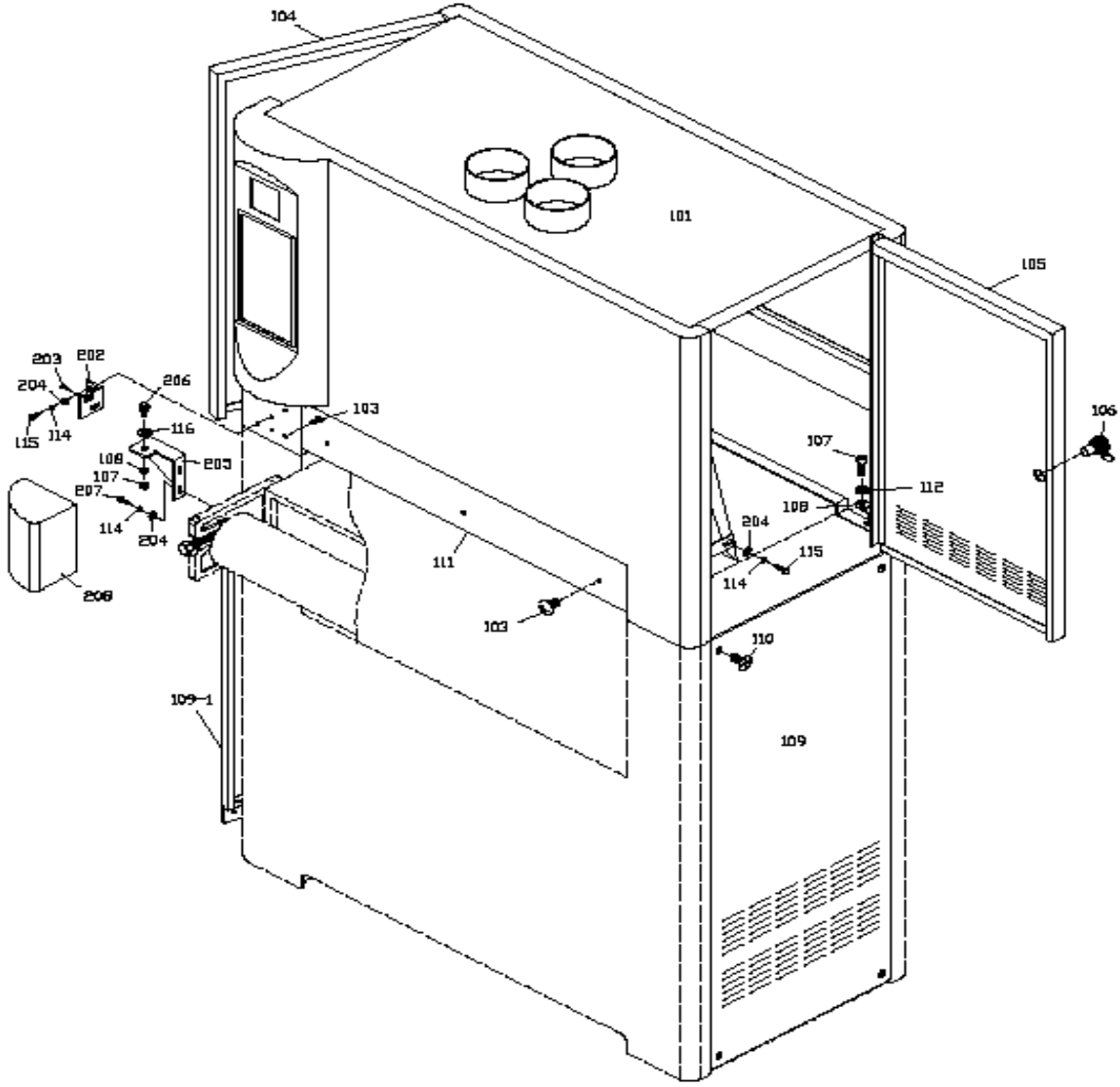

7000	
ITEM NO	DESCRIPTION
101	UPPER FRAME COVER
103	PHILLIP'S SCREW
104	LEFT DOOR, UPPER FRAME
105	RIGHT DOOR, UPPER FRAME
106	DOOR LOCK
107	SCREW
108	PLAIN WASHER 5/16"
109	RIGHT DOOR, LOWER FRAME
109-1	LEFT DOOR, LOWER FRAME
110	SCREW 1/4" X 1/2"
111	FRONT PROTECTION PLATE

# ELECTRICAL PARTS - 37 1K - SINGLE PHASE

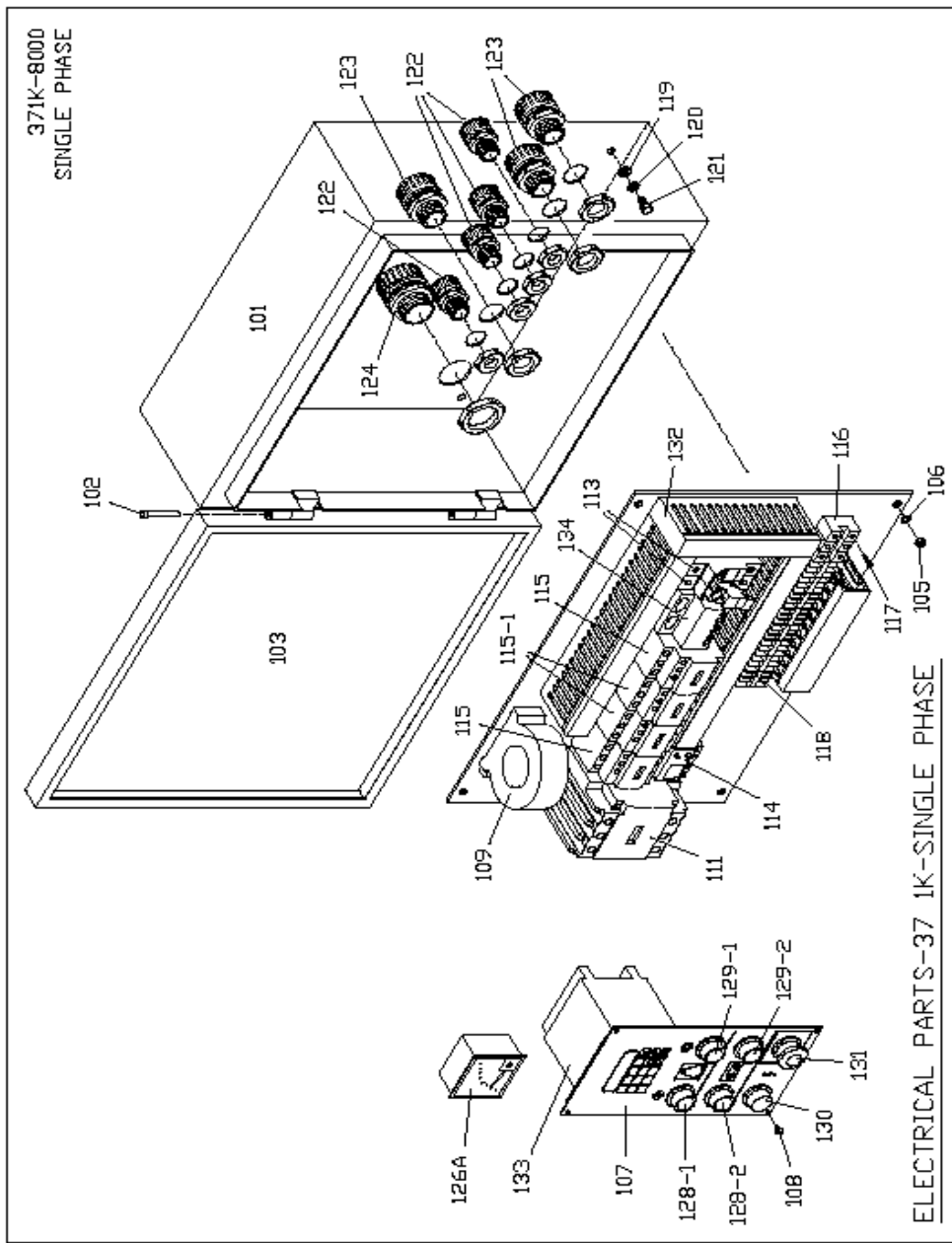

8000		8000	
ITEM NO	DESCRIPTION	ITEM NO	DESCRIPTION
101	ELECTRICAL CONTROL BOX	128-1	START SWITCH
102	HINGE	128-2	START SWITCH
103	ELECTRICAL CONTROL BOX OF DOOR	129-1	STOP SWITCH
104	BASE PLATE	129-2	STOP SWITCH
105	NUT 1/4"	130	POWER INDICATION LIGHT
106	SPRING WASHER 1/4"	131	EMERGENCY STOP SWITCH
107	CONTROL PANEL	132	WIRE COLUMN
108	PHILLIP'S SCREW M4 X 8MM	133	COMPUTER
109	PROPORTIONAL CURRENT DEVICE	134	OVERLOAD RELAY
110	TRANSFORMER: 3PH ONLY		
111	CONTACTOR		
113	FUSE		
114	OVERLOAD RELAY		
115	CONTACTOR		
115-1	CONTACTOR WITH LOCK		
116	POWER WIRE TERMINAL		
117	PHILLIP'S SCREW M4 X 30MM		
118	TERMINAL PLATE		
119	PLAIN WASHER 1/4"		
120	SPRING WASHER 1/4"		
121	SCREW 1/4" X 1/2"		
122	PU CONNECTOR 1/2"		
123	PU CONNECTOR 3/4"		
124	CABLE CONNECTOR 1"		
126A	AMP METER		



371K-9000

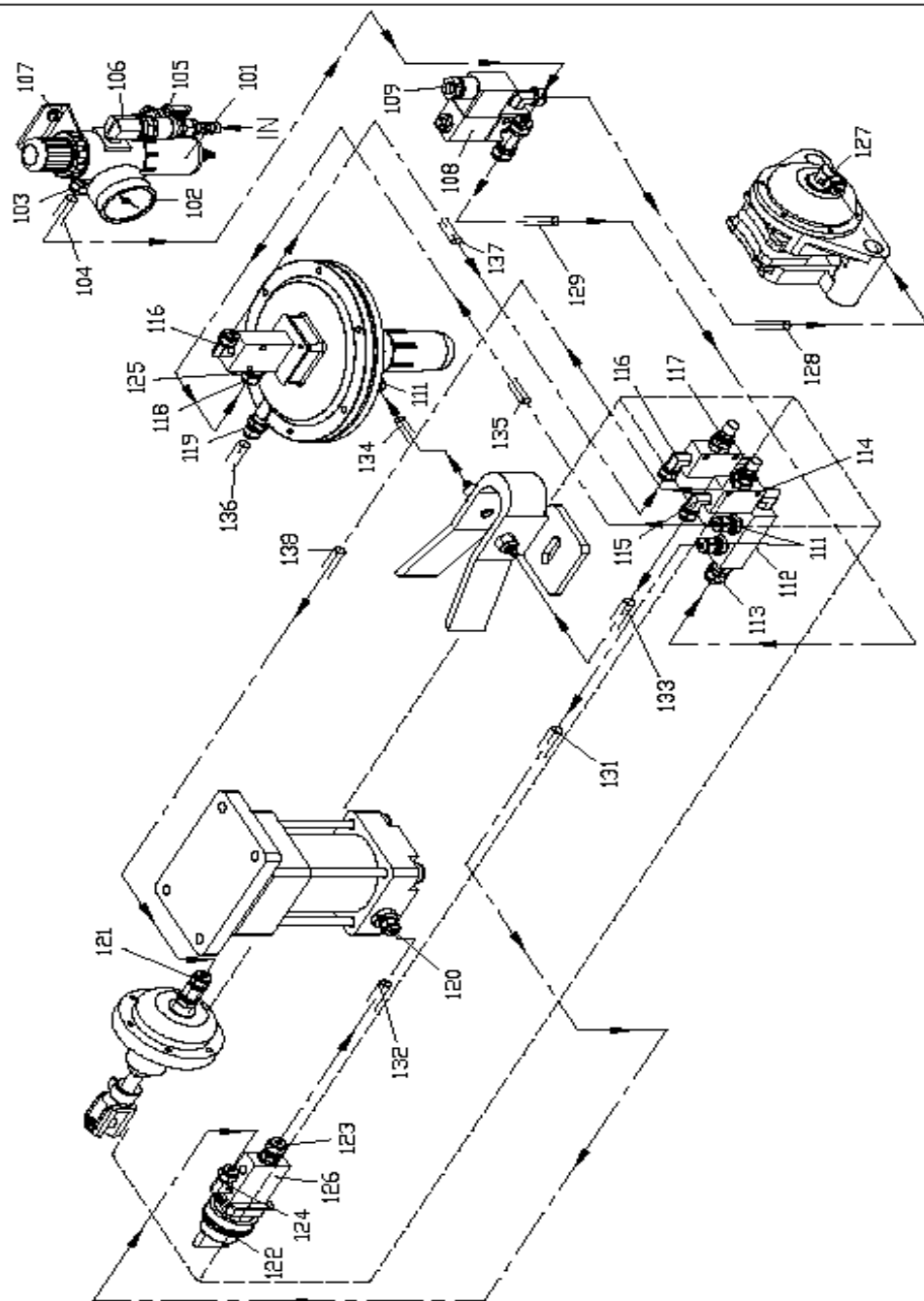

9000		9000	
ITEM NO	DESCRIPTION	ITEM NO	DESCRIPTION
101	FILTER CUP	128	FLEXIBLE HOSE
102	PRESSURE GAUGE	129	FLEXIBLE HOSE
103	BRONZE CONNECTOR	131	FLEXIBLE HOSE
104	FLEXIBLE HOSE	132	FLEXIBLE HOSE
105	AIR SWITCH	133	FLEXIBLE HOSE
106	ELBOW	134	FLEXIBLE HOSE
107	SCREW 3/16"	135	FLEXIBLE HOSE
108	ELBOW	136	FLEXIBLE HOSE
109	SOLENOID VALVE	137	FLEXIBLE HOSE
110	T-JOINT	138	FLEXIBLE HOSE
111	CONNECTOR		
112	MULTIPLE HOLE CONNECTOR		
113	CONNECTOR		
114	BRONZE ELBOW		
115	CONNECTOR		
116	CONNECTOR		
117	THROTTLE VALVE		
118	CONNECTOR		
119	BRONZE CONNECTOR		
120	CONNECTOR		
121	CONNECTOR		
122	AIR SWITCH		
123	CONNECTOR		
124	CONNECTOR		
125	BUFFER		
127	CONNECTOR		

# **LAGUNA**

2072 Alton Parkway. Irvine, CA 92606  
Ph: 800.234.1976 | [www.lagunatools.com](http://www.lagunatools.com)

Laguna Tools is not responsible for errors or omissions.  
Specifications subject to change. Machines may be shown with optional accessories.

© 2018, Laguna Tools, Inc. LAGUNA® and the LAGUNA Logo® are the  
registered trademarks of Laguna Tools, Inc. All rights reserved.